



(19) **United States**

(12) **Patent Application Publication** (10) **Pub. No.: US 2020/0201482 A1**

WEISSE et al.

(43) **Pub. Date: Jun. 25, 2020**

(54) **ULTRA-THIN TOUCH SENSORS**

(52) **U.S. Cl.**

(71) Applicant: **Apple Inc.**, Cupertino, CA (US)

CPC **G06F 3/0443** (2019.05); **G06F 3/04166** (2019.05); **G06F 2203/04102** (2013.01)

(72) Inventors: **Jeffrey M. WEISSE**, Santa Clara, CA (US); **Chun-Hao TUNG**, Santa Clara, CA (US); **Ji Hun CHOI**, Los Gatos, CA (US); **Wenqing DAI**, San Jose, CA (US)

(57)

ABSTRACT

Touch screens with ultra-thin stack-ups can provide for a lower profile device, can improve the optical image on the display by reducing the display to cover glass distance, and can reduce the weight of the device. In some examples, the thickness of the touch screen stack-up can be reduced and/or the border region reduced, by removing the flex circuit connection from the stack-up. A flexible substrate can be used to enable routing of touch electrodes to touch circuitry. In some examples including a shield layer, the thickness of the touch screen stack-up can be reduced by routing the shield layer to a shield electrode on the touch sensor panel. The shield layer can then be routed to touch sensing circuitry via the flexible substrate. In some examples, the touch sensor panel or a portion of thereof can be integrated with the polarizer.

(21) Appl. No.: **16/712,339**

(22) Filed: **Dec. 12, 2019**

Related U.S. Application Data

(60) Provisional application No. 62/782,264, filed on Dec. 19, 2018.

Publication Classification

(51) **Int. Cl.**
G06F 3/044 (2006.01)

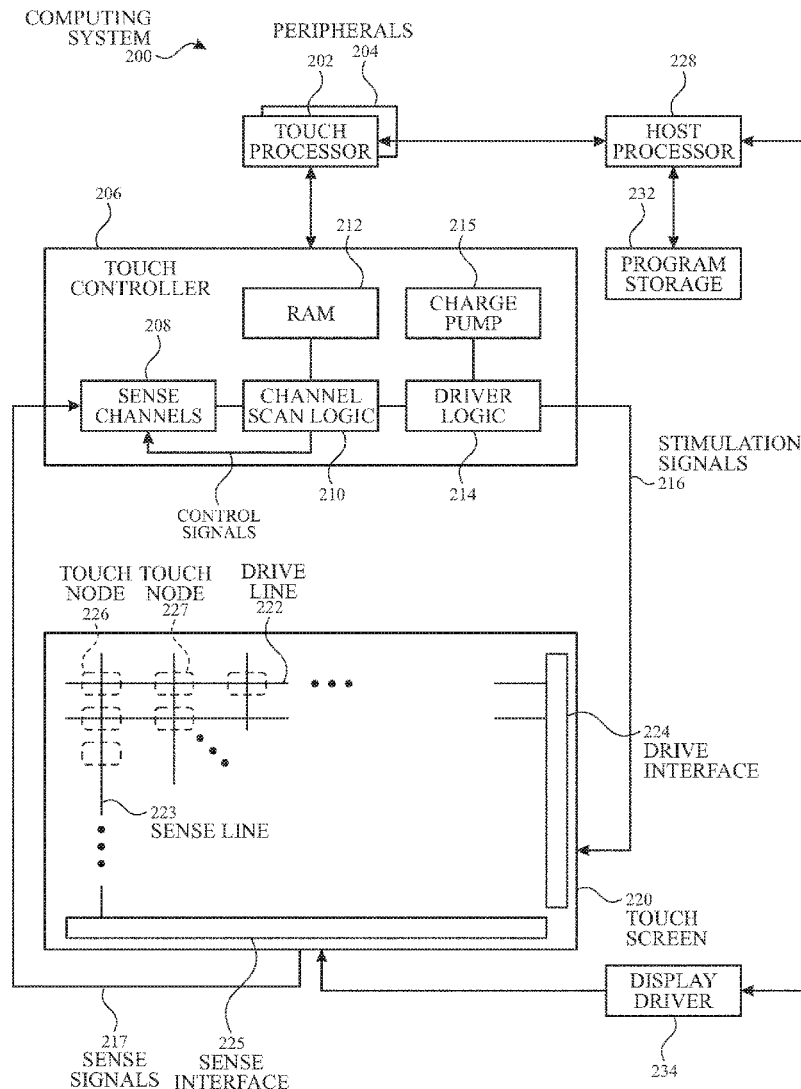

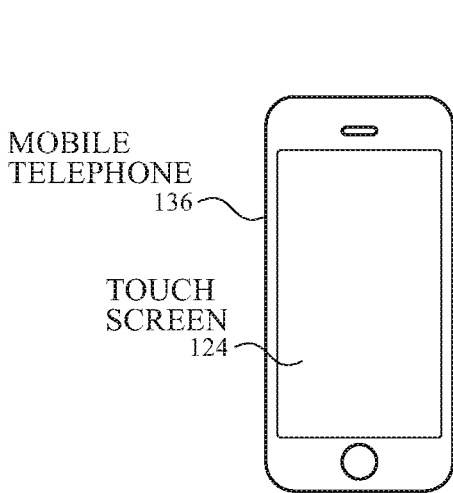

FIG. 1A

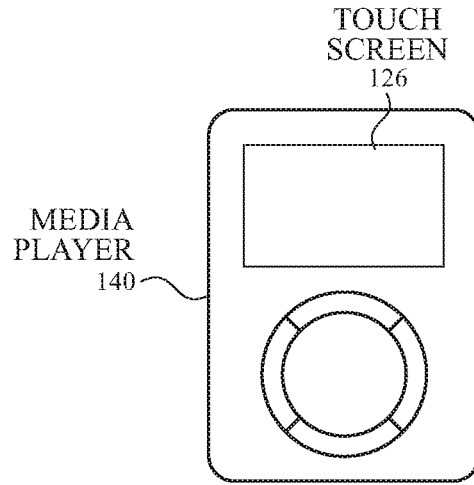

FIG. 1B

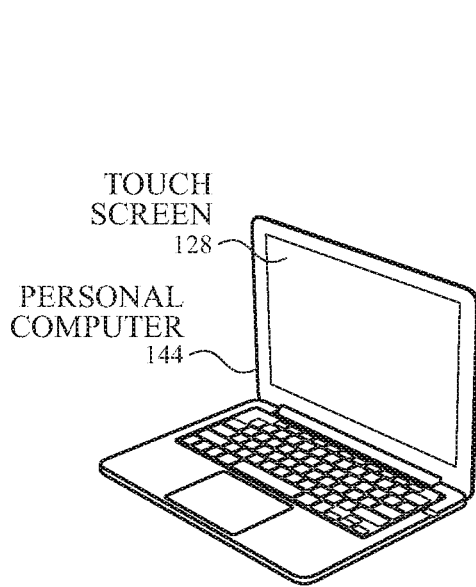

FIG. 1C

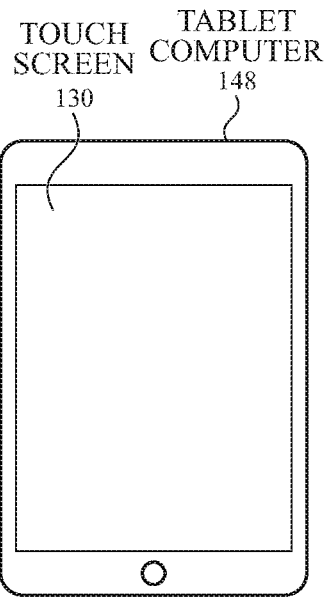

FIG. 1D

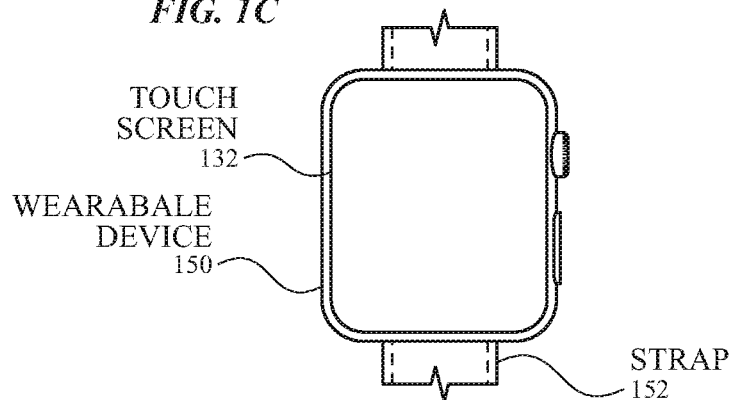

FIG. 1E

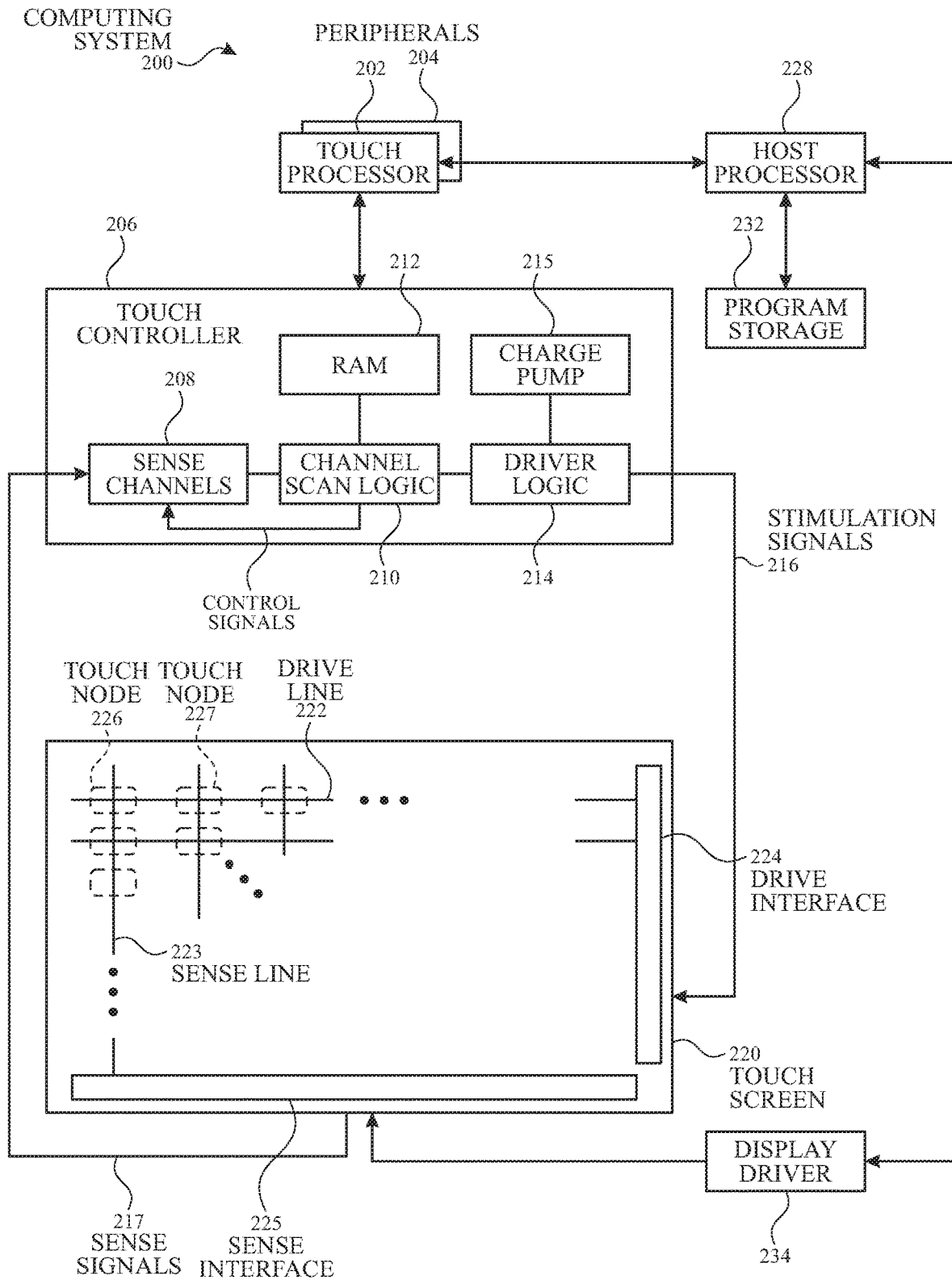

FIG. 2

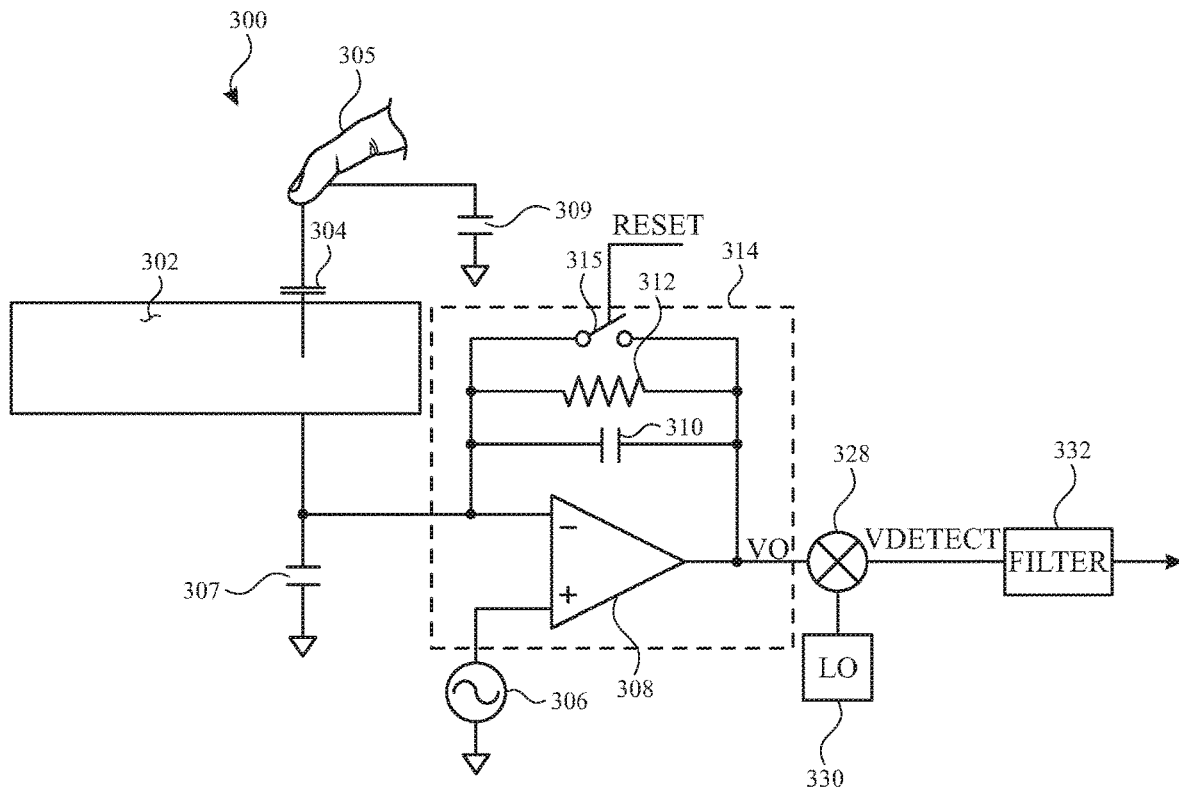

FIG. 3A

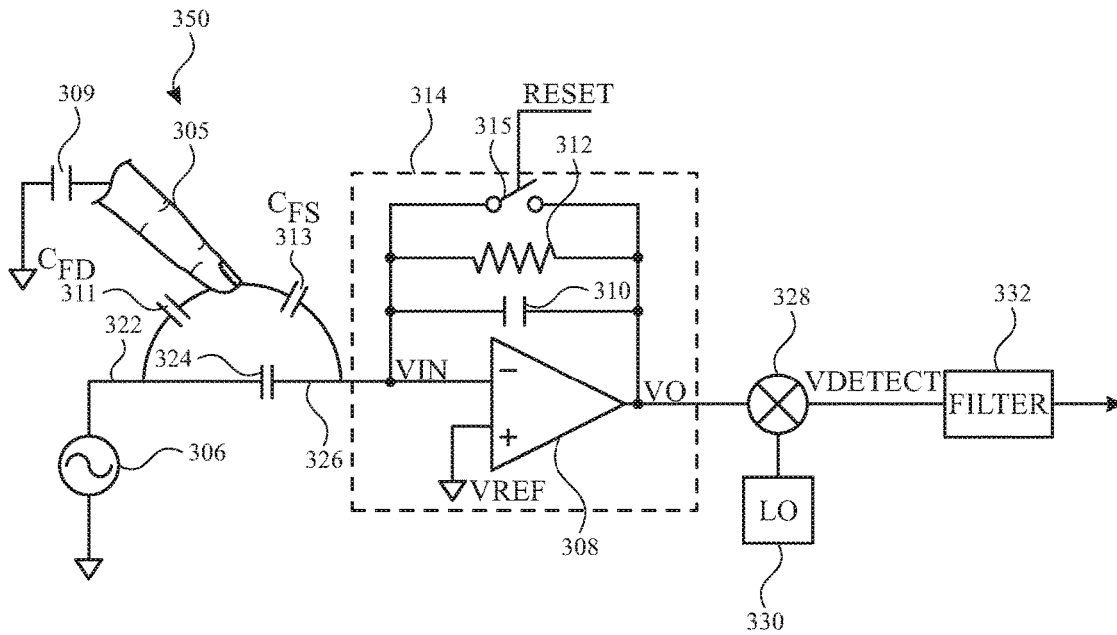

FIG. 3B

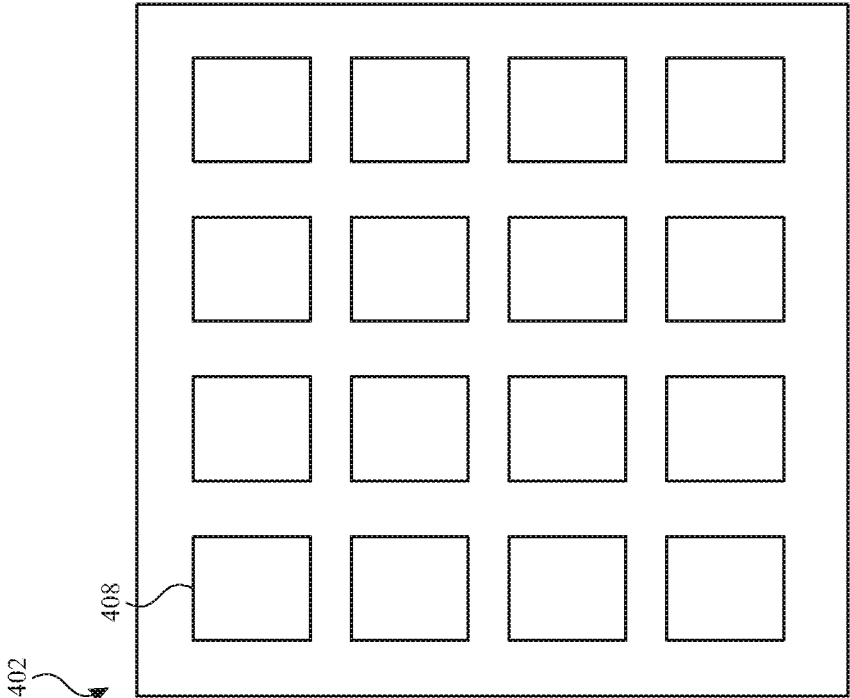

FIG. 4B

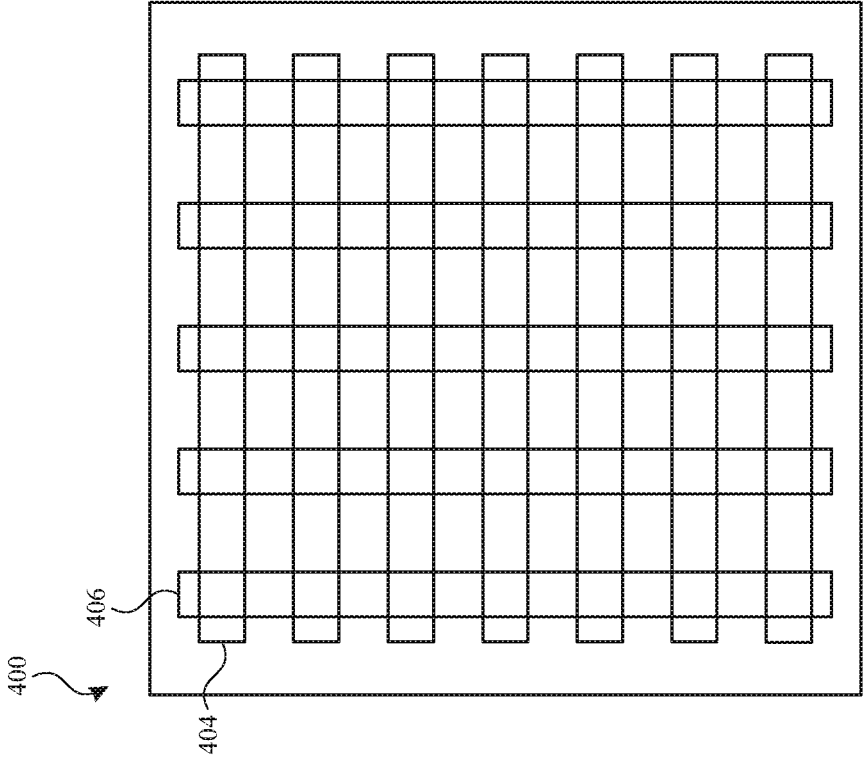

FIG. 4A

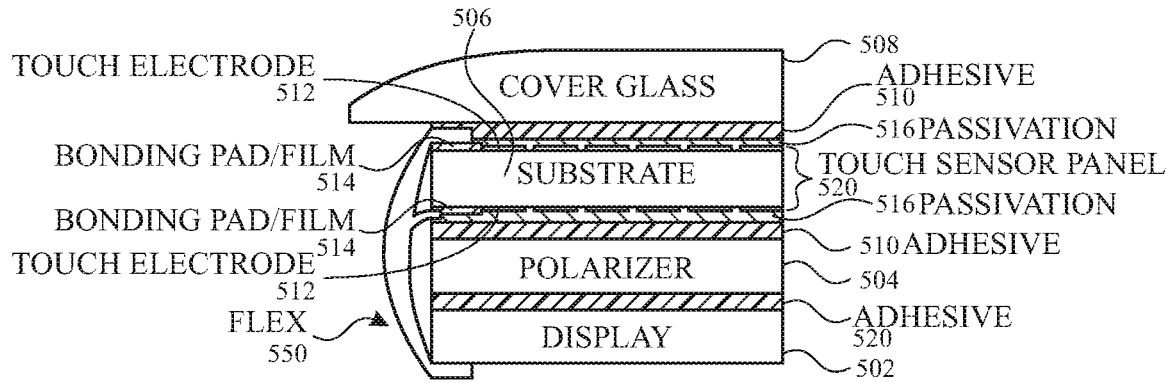

FIG. 5A

504 ↗

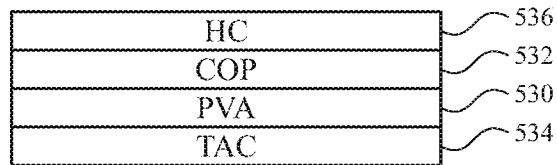

FIG. 5B

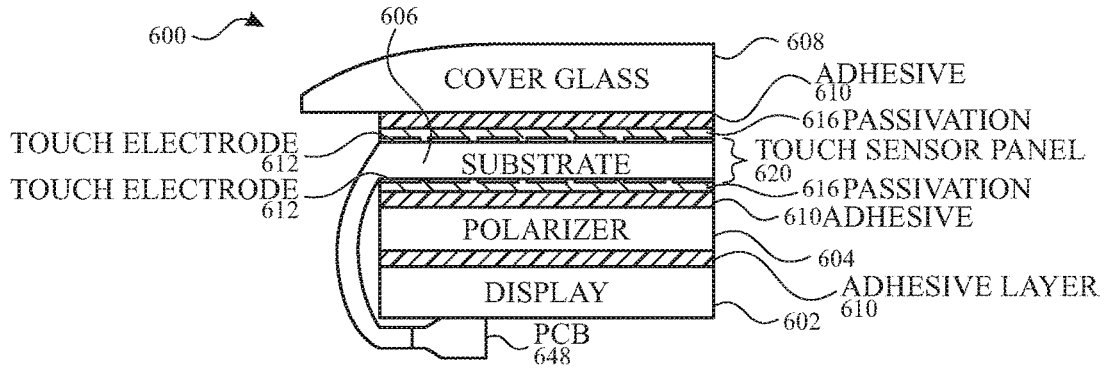

FIG. 6A

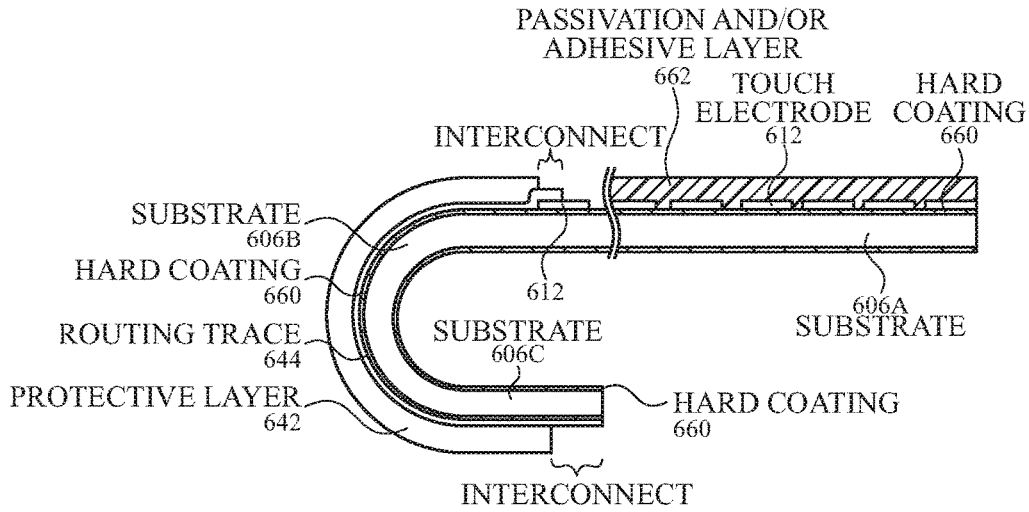

FIG. 6B

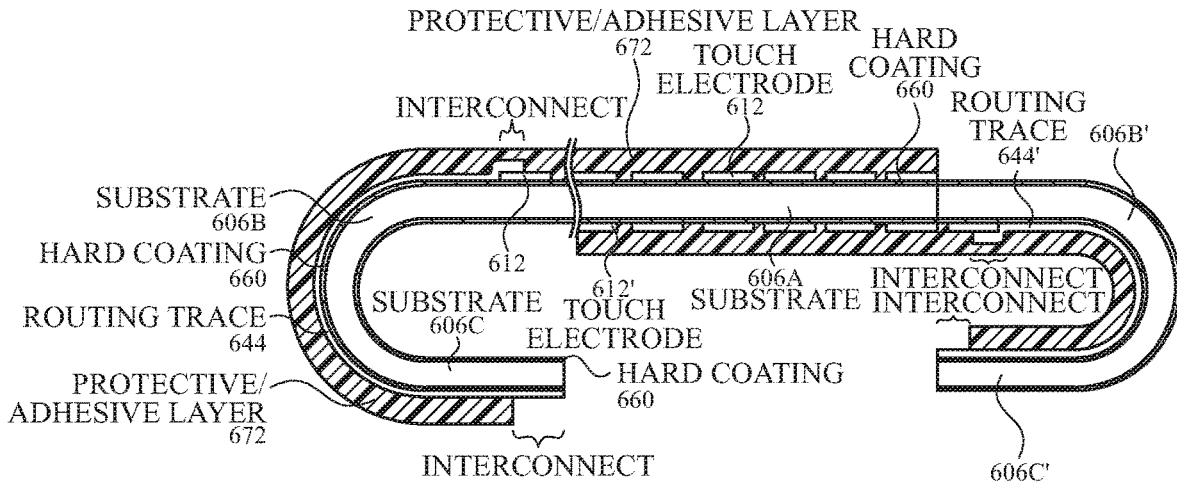

FIG. 6C

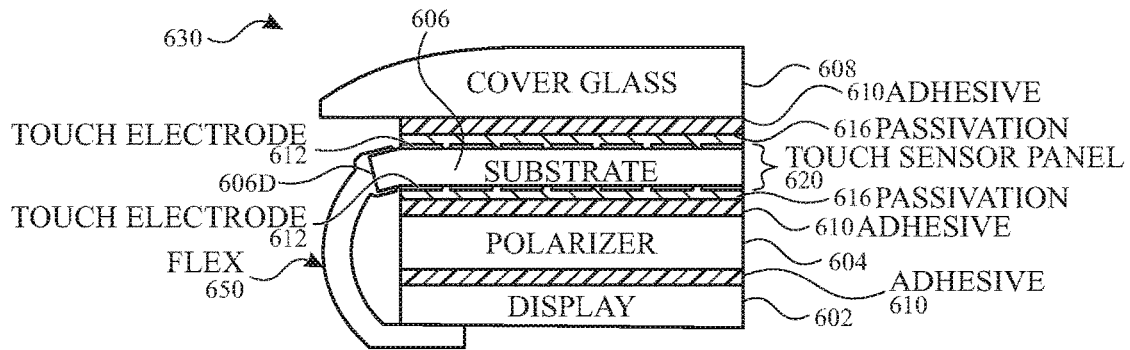

FIG. 6D

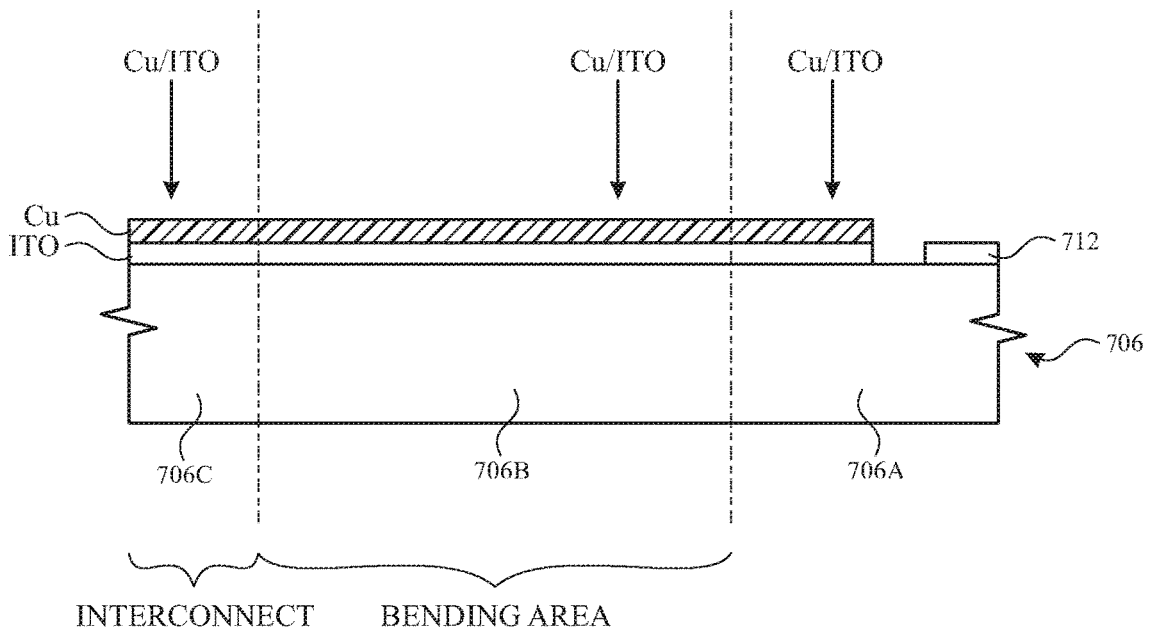

FIG. 7A

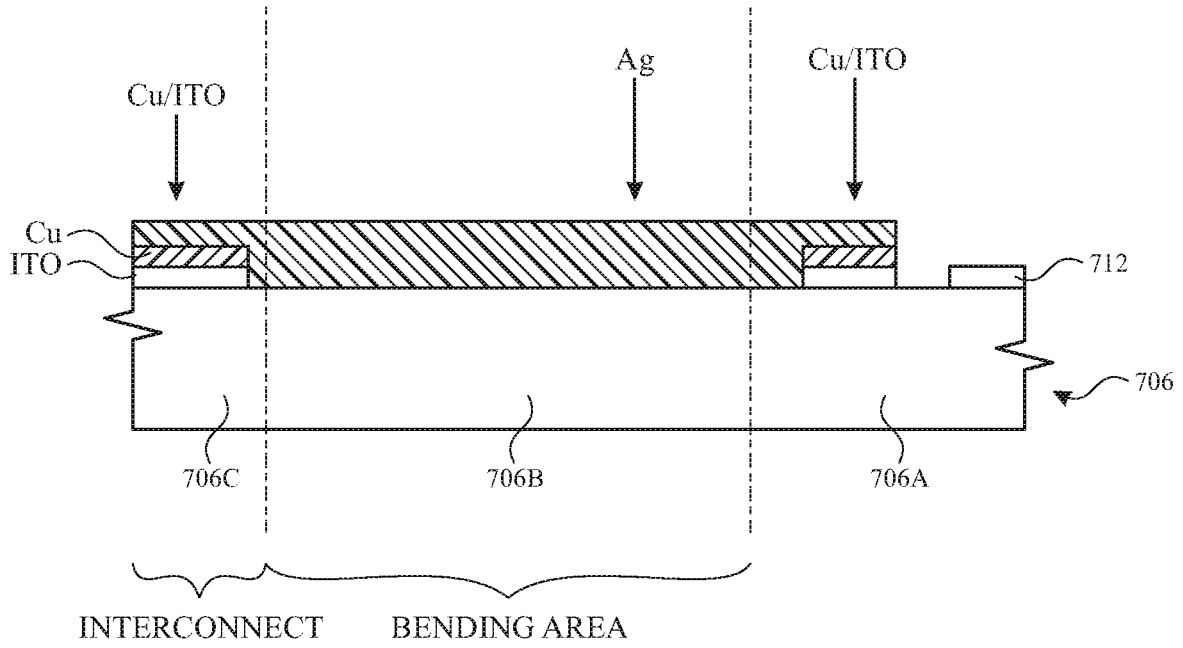

FIG. 7B

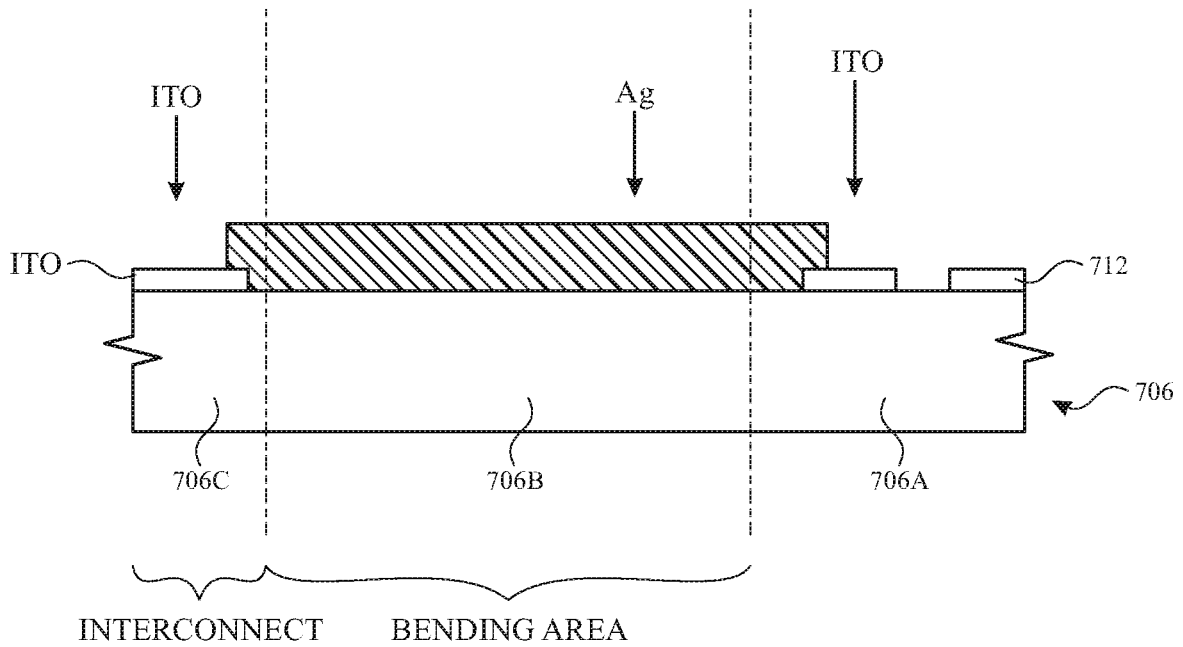

FIG. 7C

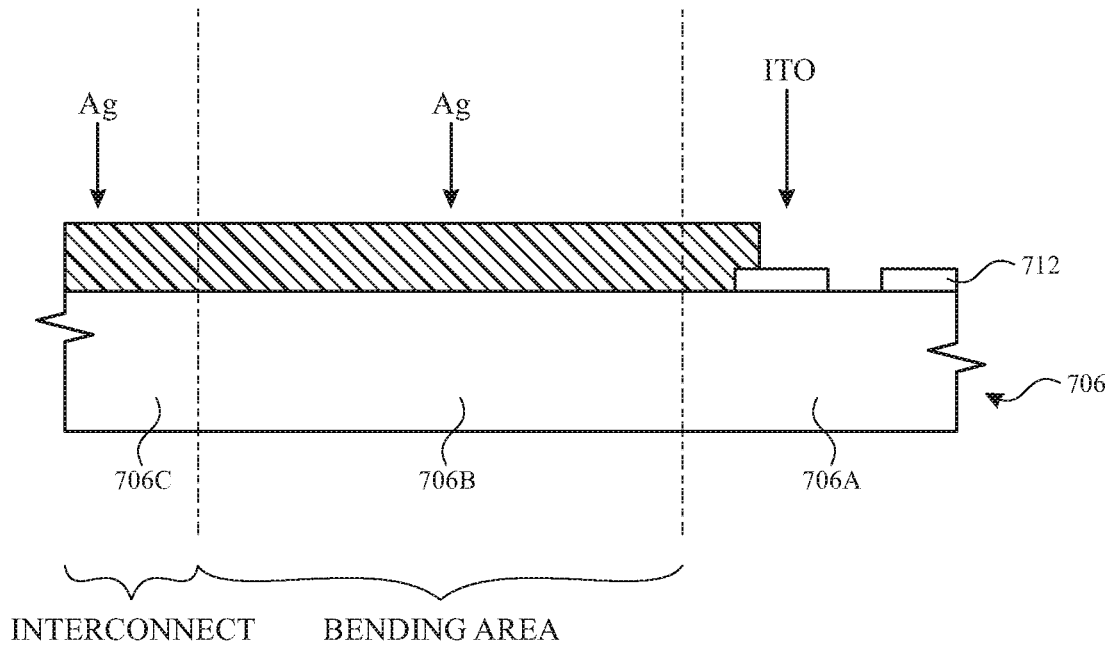

FIG. 7D

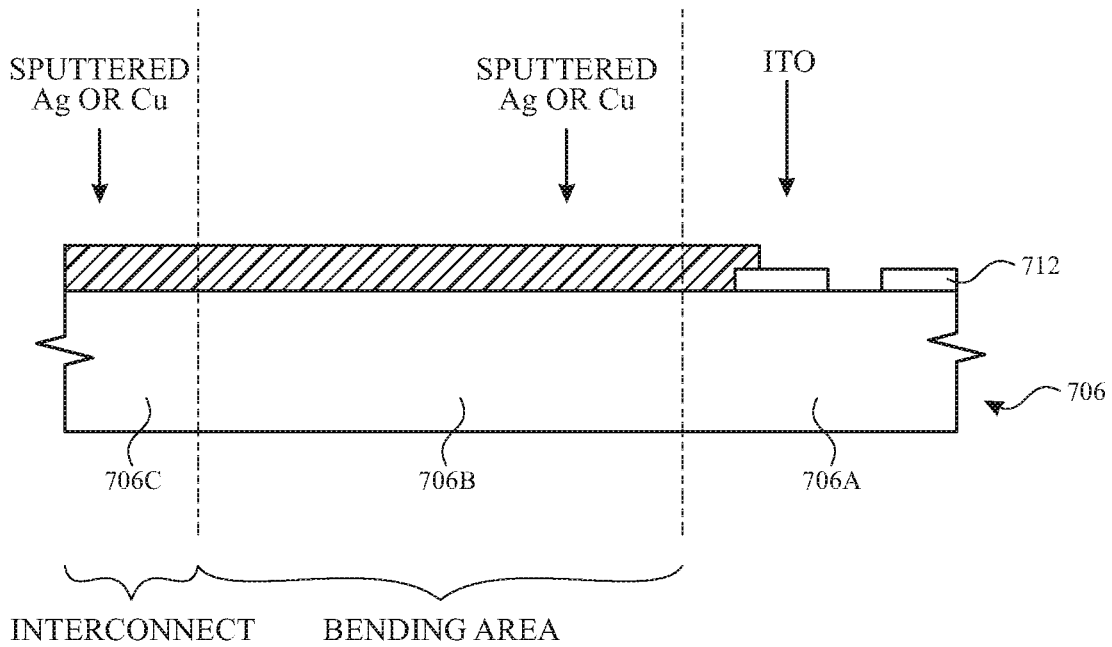

FIG. 7E

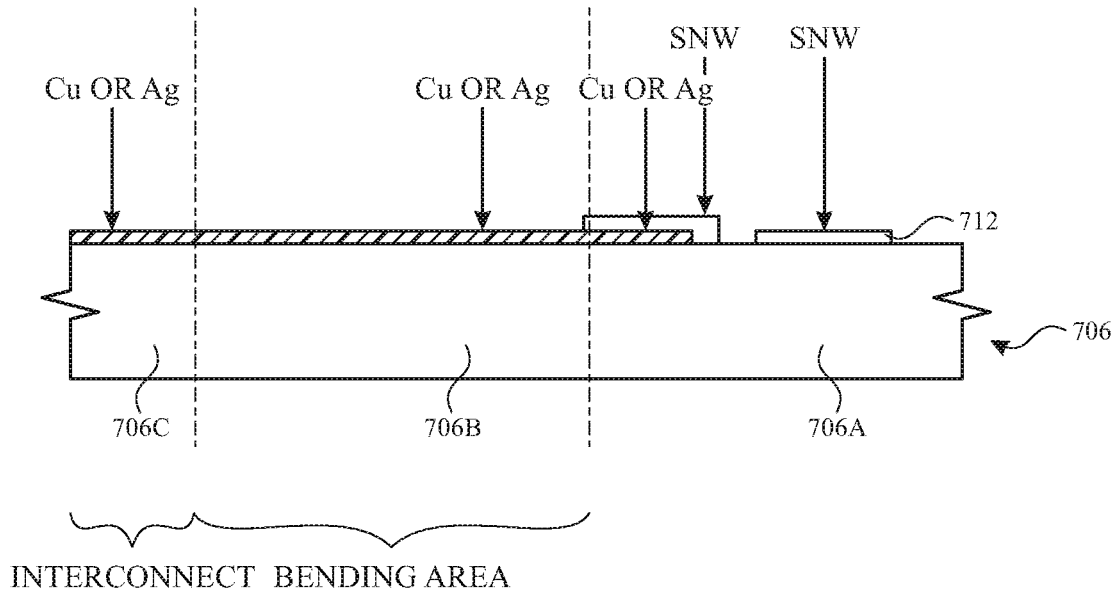

FIG. 7F

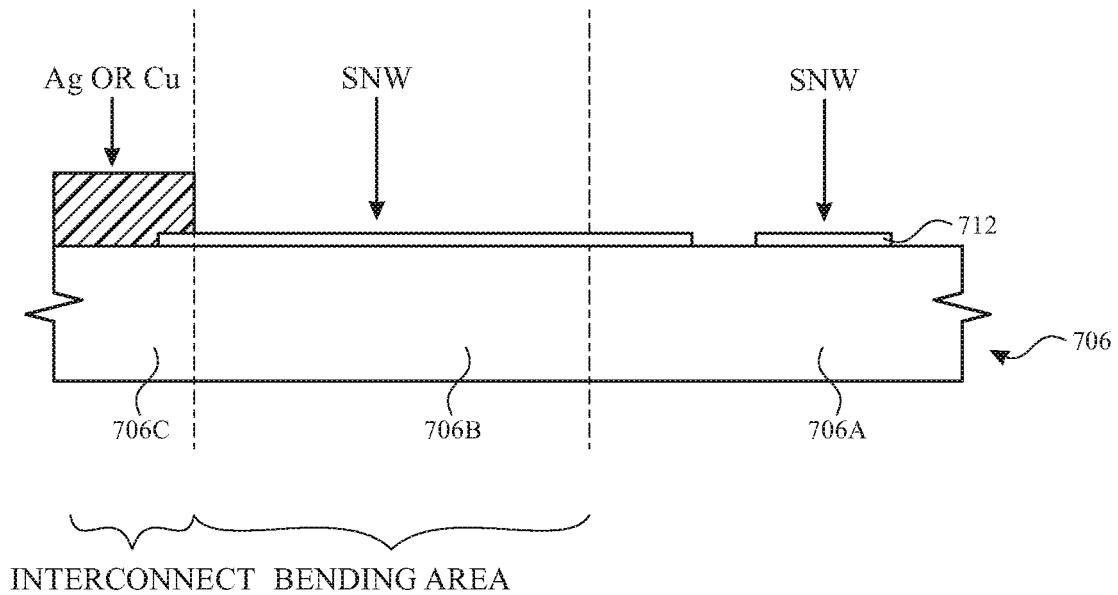

FIG. 7G

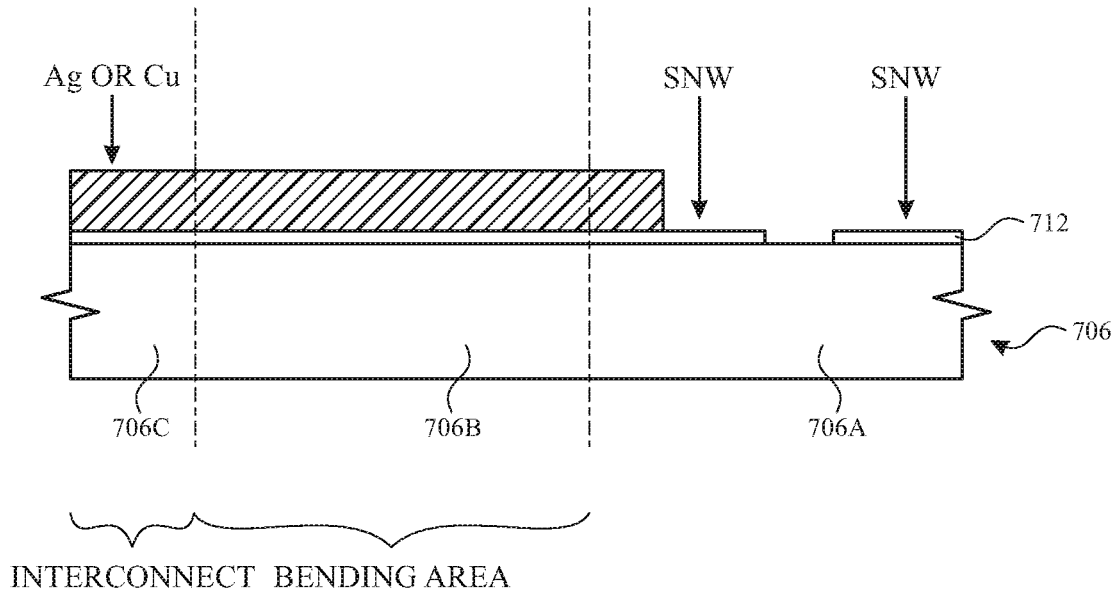

FIG. 7H

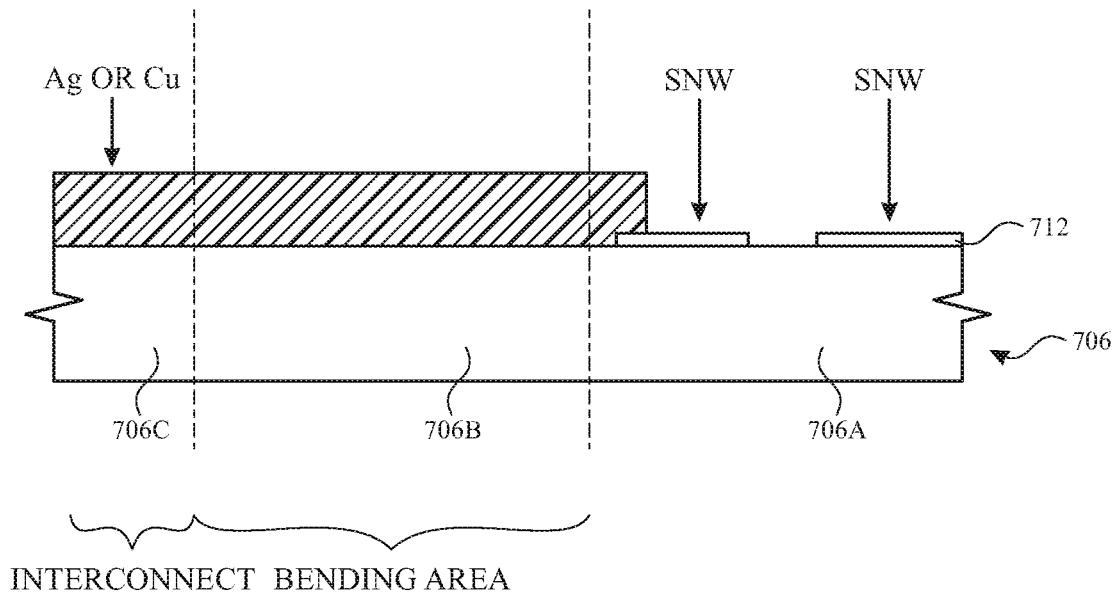

FIG. 7I

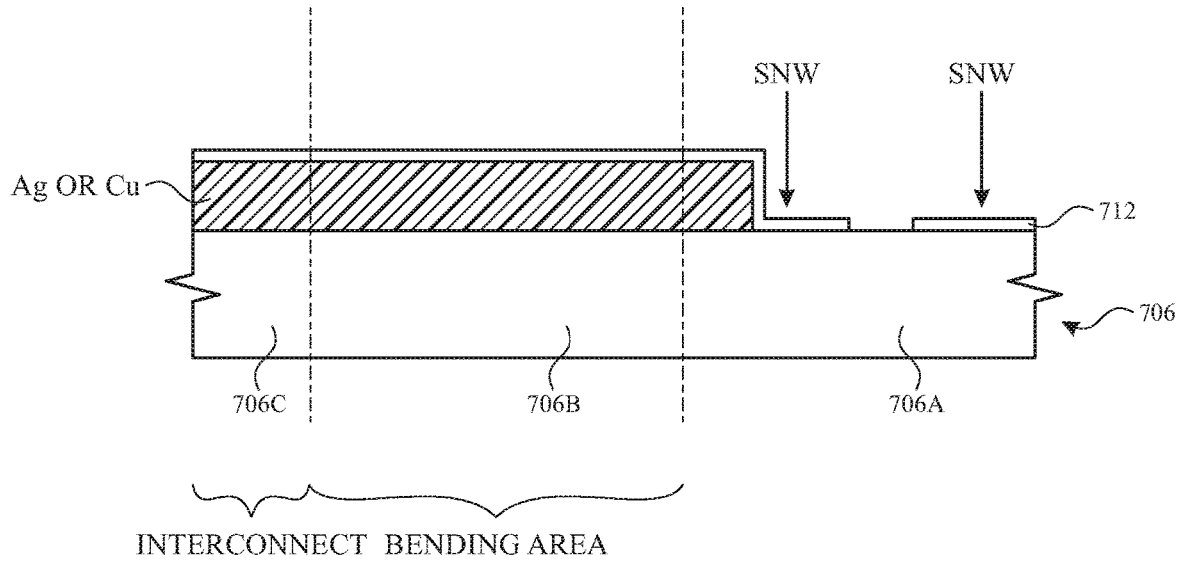

FIG. 7J

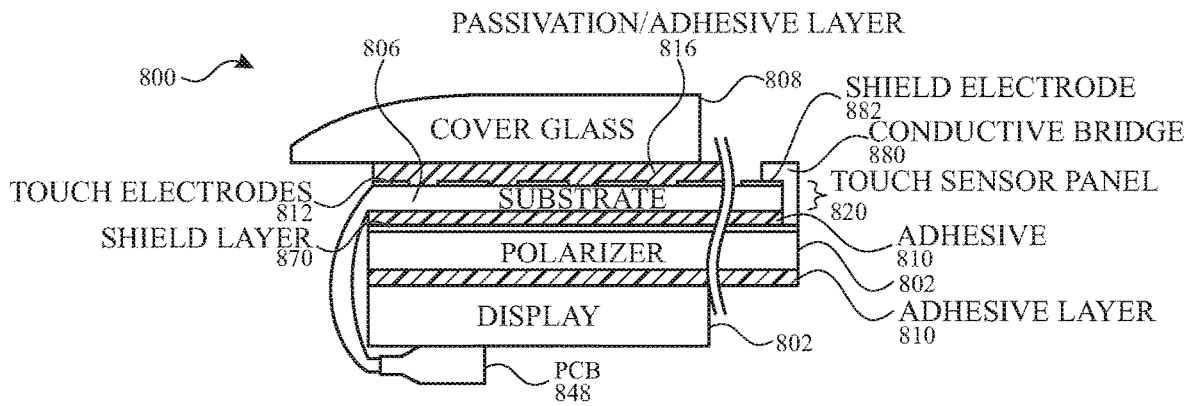

FIG. 8A

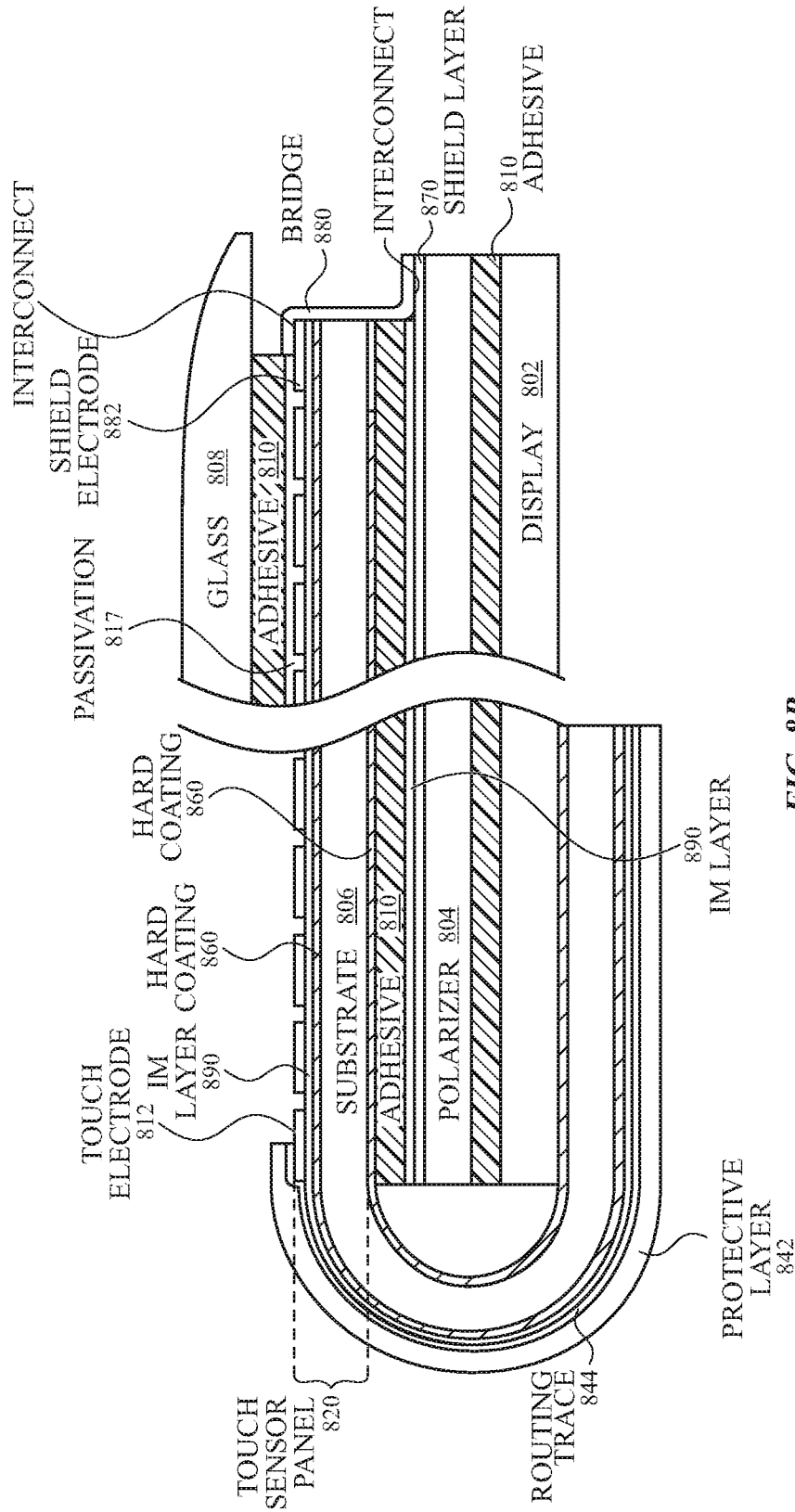

FIG. 8B

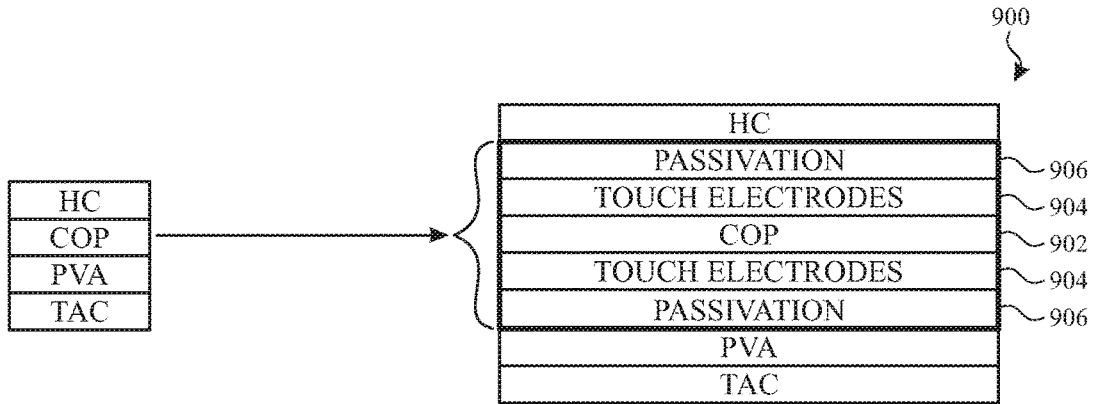

FIG. 9

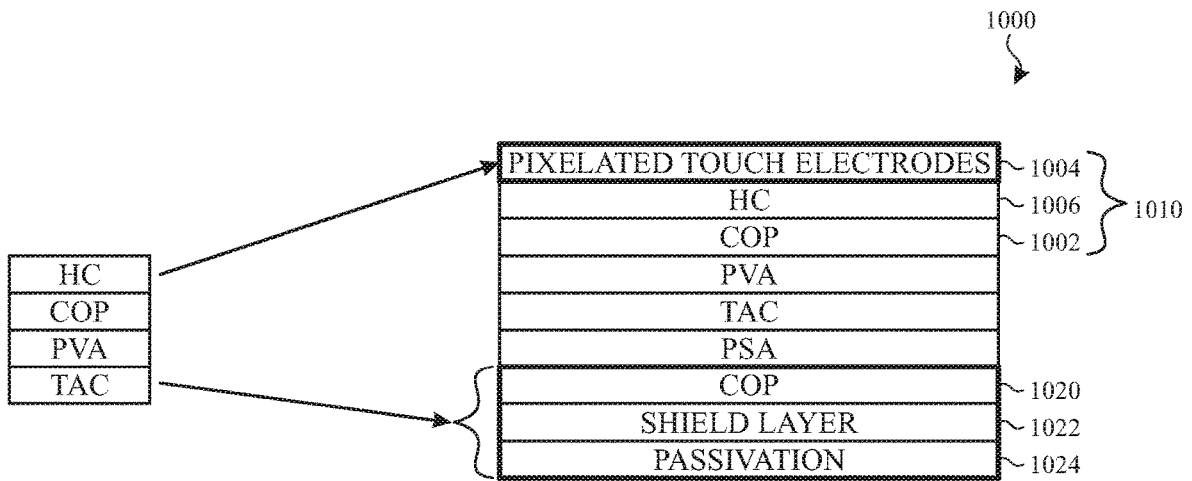

FIG. 10

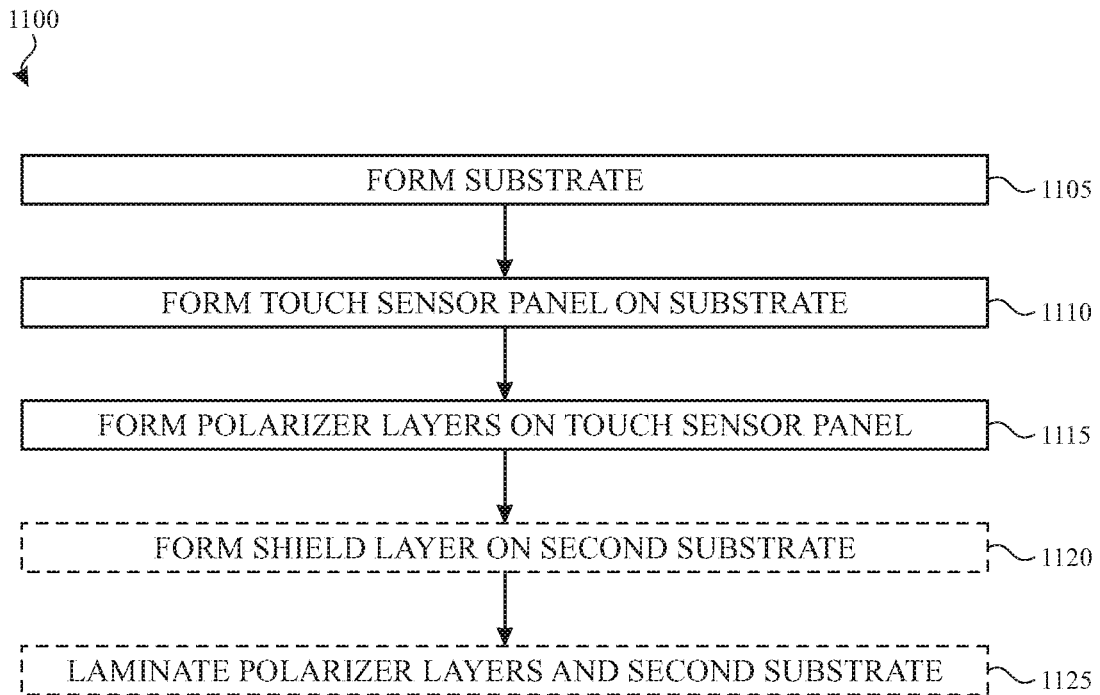

FIG. 11

ULTRA-THIN TOUCH SENSORS

CROSS-REFERENCE TO RELATED APPLICATIONS

[0001] This application claims the benefit under 35 USC 119(e) of U.S. Provisional Patent Application No. 62/782,264, filed Dec. 19, 2018 the contents of which are incorporated herein by reference in their entirety for all purposes.

FIELD OF THE DISCLOSURE

[0002] This relates generally to touch screens, and more particularly, to touch screens with ultra-thin stack-ups.

BACKGROUND OF THE DISCLOSURE

[0003] Many types of input devices are presently available for performing operations in a computing system, such as buttons or keys, mice, trackballs, joysticks, touch sensor panels, touch screens and the like. Touch screens, in particular, are popular because of their ease and versatility of operation as well as their declining price. Touch screens can include a touch sensor panel, which can be a clear panel with a touch-sensitive surface, and a display device such as a liquid crystal display (LCD), light emitting diode (LED) display or organic light emitting diode (OLED) display that can be positioned partially or fully behind the panel so that the touch-sensitive surface can cover at least a portion of the viewable area of the display device. Touch screens can allow a user to perform various functions by touching the touch sensor panel using a finger, stylus or other object at a location often dictated by a user interface (UI) being displayed by the display device. In general, touch screens can recognize a touch and the position of the touch on the touch sensor panel, and the computing system can then interpret the touch in accordance with the display appearing at the time of the touch, and thereafter can perform one or more actions based on the touch. In the case of some touch sensing systems, a physical touch on the display is not needed to detect a touch. For example, in some capacitive-type touch sensing systems, fringing electrical fields used to detect touch can extend beyond the surface of the display, and objects approaching near the surface may be detected near the surface without actually touching the surface.

[0004] Capacitive touch sensor panels can be formed by a matrix of partially or fully transparent or non-transparent conductive plates (e.g., touch electrodes) made of materials such as Indium Tin Oxide (ITO). It is due in part to their substantial transparency that some capacitive touch sensor panels can be overlaid on a display to form a touch screen, as described above. Some touch screens can be formed by at least partially integrating touch sensing circuitry into a display pixel stack-up (i.e., the stacked material layers forming the display pixels).

SUMMARY OF THE DISCLOSURE

[0005] This relates to touch screens with ultra-thin stack-ups. Reducing the thickness of the touch screen can provide for a lower profile device, can improve the optical image on the display by reducing the display to cover glass distance, and can reduce the weight of the device. In some examples, the thickness of the touch screen stack-up can be reduced and/or the border region reduced, by removing the flex circuit connection from the stack-up. A flexible substrate can be used to enable routing of touch electrodes to touch

circuitry. In some examples, the touch screen stack-up can include a shield layer between the touch sensor panel and the display. In some examples, the thickness of the touch screen stack-up including a shield layer can be reduced by routing the shield layer to a shield electrode on the touch sensor panel. The shield layer can then be routed to touch sensing circuitry via the flexible substrate. Additionally, or alternatively, in some examples, as described herein, the touch sensor panel or a portion of thereof can be integrated with the polarizer. Integrating the touch sensor panel with the polarizer can reduce the thickness of the touch screen stack-up because one substrate can be used for the touch sensor panel and polarizer in place of separate substrates for each of the touch sensor panel and the polarizer.

BRIEF DESCRIPTION OF THE DRAWINGS

[0006] FIGS. 1A-1E illustrate example systems that can include touch screens with ultra-thin stack-ups according to examples of the disclosure.

[0007] FIG. 2 illustrates an example computing system including a touch screen according to examples of the disclosure.

[0008] FIG. 3A illustrates an exemplary touch sensor circuit corresponding to a self-capacitance measurement of a touch node electrode and sensing circuit according to examples of the disclosure.

[0009] FIG. 3B illustrates an exemplary touch sensor circuit corresponding to a mutual-capacitance drive line and sense line and sensing circuit according to examples of the disclosure.

[0010] FIG. 4A illustrates a touch screen with touch electrodes arranged in rows and columns according to examples of the disclosure.

[0011] FIG. 4B illustrates a touch screen with touch node electrodes arranged in a pixelated touch node electrode configuration according to examples of the disclosure.

[0012] FIG. 5A illustrates an exemplary touch screen that can be used in a touch sensitive device according to examples of the disclosure.

[0013] FIG. 5B illustrates an exemplary polarizer stack-up according to examples of the disclosure.

[0014] FIGS. 6A-6D illustrate examples of touch screen stack-ups with a flexible substrate according to examples of the disclosure.

[0015] FIGS. 7A-7J illustrate examples of flexible substrates and routing according to examples of the disclosure.

[0016] FIGS. 8A-8B illustrate an example of touch screen stack-up with a shield layer routed to the touch sensor panel examples of the disclosure.

[0017] FIGS. 9 and 10 illustrate examples of an integrated touch sensor panel and polarizer according to examples of the disclosure.

[0018] FIG. 11 illustrates an exemplary process for forming an integrated touch sensor panel and polarizer according to examples of the disclosure.

DETAILED DESCRIPTION

[0019] In the following description of examples, reference is made to the accompanying drawings which form a part hereof, and in which it is shown by way of illustration specific examples that can be practiced. It is to be under-

stood that other examples can be used and structural changes can be made without departing from the scope of the disclosed examples.

[0020] This relates to touch screens with ultra-thin stack-ups. Reducing the thickness of the touch screen can provide for a lower profile device, can improve the optical image on the display by reducing the display to cover glass distance, and can reduce the weight of the device. In some examples, the thickness of the touch screen stack-up can be reduced and/or the border region reduced, by removing the flex circuit connection from the stack-up. A flexible substrate can be used to enable routing of touch electrodes to touch circuitry.

[0021] In some examples, the touch screen stack-up can include a shield layer between the touch sensor panel and the display. In some examples, the thickness of the touch screen stack-up including a shield layer can be reduced by routing the shield layer to a shield electrode on the touch sensor panel. The shield layer can then be routed to touch sensing circuitry via the flexible substrate.

[0022] Additionally, or alternatively, in some examples, as described herein, the touch sensor panel or a portion of thereof can be integrated with the polarizer. Integrating the touch sensor panel with the polarizer can reduce the thickness of the touch screen stack-up because one substrate can be used for the touch sensor panel and polarizer in place of separate substrates for each of the touch sensor panel and the polarizer.

[0023] FIGS. 1A-1E illustrate example systems that can include touch screens with ultra-thin stack-ups according to examples of the disclosure. FIG. 1A illustrates an example mobile telephone 136 that includes a touch screen 124 that can be implemented with ultra-thin stack-ups according to examples of the disclosure. FIG. 1B illustrates an example digital media player 140 that includes a touch screen 126 that can be implemented with ultra-thin stack-ups according to examples of the disclosure. FIG. 1C illustrates an example personal computer 144 that includes a touch screen 128 that can be implemented with ultra-thin stack-ups according to examples of the disclosure. FIG. 1D illustrates an example tablet computing device 148 that includes a touch screen 130 that can be implemented with ultra-thin stack-ups according to examples of the disclosure. FIG. 1E illustrates an example wearable device 150 that includes a touch screen 132 and can be attached to a user using a strap 152 and that can be implemented with ultra-thin stack-ups according to examples of the disclosure. It is understood that a touch screen with ultra-thin stack-ups can be implemented in other devices as well.

[0024] In some examples, touch screens 124, 126, 128, 130 and 132 can be based on self-capacitance. A self-capacitance based touch system can include a matrix of small, individual plates of conductive material or groups of individual plates of conductive material forming larger conductive regions that can be referred to as touch electrodes or as touch node electrodes (as described below with reference to FIG. 4B). For example, a touch screen can include a plurality of individual touch electrodes, each touch electrode identifying or representing a unique location (e.g., a touch node) on the touch screen at which touch or proximity is to be sensed, and each touch node electrode being electrically isolated from the other touch node electrodes in the touch screen/panel. Such a touch screen can be referred to as a pixelated self-capacitance touch screen,

though it is understood that in some examples, the touch node electrodes on the touch screen can be used to perform scans other than self-capacitance scans on the touch screen (e.g., mutual capacitance scans). During operation, a touch node electrode can be stimulated with an alternating current (AC) waveform, and the self-capacitance to ground of the touch node electrode can be measured. As an object approaches the touch node electrode, the self-capacitance to ground of the touch node electrode can change (e.g., increase). This change in the self-capacitance of the touch node electrode can be detected and measured by the touch sensing system to determine the positions of multiple objects when they touch, or come in proximity to, the touch screen. In some examples, the touch node electrodes of a self-capacitance based touch system can be formed from rows and columns of conductive material, and changes in the self-capacitance to ground of the rows and columns can be detected, similar to above. In some examples, a touch screen can be multi-touch, single touch, projection scan, full-imaging multi-touch, capacitive touch, etc.

[0025] In some examples, touch screens 124, 126, 128, 130 and 132 can be based on mutual capacitance. A mutual capacitance based touch system can include electrodes arranged as drive and sense lines that may cross over each other on different layers (in a double-sided configuration), or may be adjacent to each other on the same layer (e.g., as described below with reference to FIG. 4A). The crossing or adjacent locations can form touch nodes. During operation, the drive line can be stimulated with an AC waveform and the mutual capacitance of the touch node can be measured. As an object approaches the touch node, the mutual capacitance of the touch node can change (e.g., decrease). This change in the mutual capacitance of the touch node can be detected and measured by the touch sensing system to determine the positions of multiple objects when they touch, or come in proximity to, the touch screen. As described herein, in some examples, a mutual capacitance based touch system can form touch nodes from a matrix of small, individual plates of conductive material.

[0026] In some examples, touch screens 124, 126, 128, 130 and 132 can be based on mutual capacitance and/or self-capacitance. The electrodes can be arranged as a matrix of small, individual plates of conductive material (e.g., as in touch node electrodes 408 in touch screen 402 in FIG. 4B) or as drive lines and sense lines (e.g., as in row touch electrodes 404 and column touch electrodes 406 in touch screen 400 in FIG. 4A), or in another pattern. The electrodes can be configurable for mutual capacitance or self-capacitance sensing or a combination of mutual and self-capacitance sensing. For example, in one mode of operation electrodes can be configured to sense mutual capacitance between electrodes and in a different mode of operation electrodes can be configured to sense self-capacitance of electrodes. In some examples, some of the electrodes can be configured to sense mutual capacitance therebetween and some of the electrodes can be configured to sense self-capacitance thereof.

[0027] FIG. 2 illustrates an example computing system including a touch screen according to examples of the disclosure, although it should be understood that the illustrated touch screen 220 (which includes a touch sensor panel) could instead be only a touch sensor panel. Computing system 200 can be included in, for example, a mobile phone, tablet, touchpad, portable or desktop computer, por-

table media player, wearable device or any mobile or non-mobile computing device that includes a touch screen or touch sensor panel. Computing system 200 can include a touch sensing system including one or more touch processors 202, peripherals 204, a touch controller 206, and touch sensing circuitry (described in more detail below). Peripherals 204 can include, but are not limited to, random access memory (RAM) or other types of memory or storage, watchdog timers and the like. Touch controller 206 can include, but is not limited to, one or more sense channels 208, channel scan logic 210 and driver logic 214. Channel scan logic 210 can access RAM 212, autonomously read data from the sense channels and provide control for the sense channels. In addition, channel scan logic 210 can control driver logic 214 to generate stimulation signals 216 at various frequencies and/or phases that can be selectively applied to drive regions of the touch sensing circuitry of touch screen 220, as described in more detail below. In some examples, touch controller 206, touch processor 202 and peripherals 204 can be integrated into a single application specific integrated circuit (ASIC), and in some examples can be integrated with touch screen 220 itself.

[0028] It should be apparent that the architecture shown in FIG. 2 is only one example architecture of computing system 200, and that the system could have more or fewer components than shown, or a different configuration of components. The various components shown in FIG. 2 can be implemented in hardware, software, firmware or any combination thereof, including one or more signal processing and/or application specific integrated circuits.

[0029] Computing system 200 can include a host processor 228 for receiving outputs from touch processor 202 and performing actions based on the outputs. For example, host processor 228 can be connected to program storage 232 and a display controller, such as a Liquid-Crystal Display (LCD) driver or more generally, display driver 234. It is understood that although some examples of the disclosure are described with reference to LCD displays, the scope of the disclosure is not so limited and can extend to other types of displays, such as Light-Emitting Diode (LED) displays, including Organic LED (OLED), Active-Matrix Organic LED (AMOLED) and Passive-Matrix Organic LED (PMOLED) displays. The display driver 234 can provide voltages on select (e.g., gate) lines to each pixel transistor and can provide data signals along data lines to these same transistors to control the pixel display image.

[0030] Host processor 228 can use display driver 234 to generate a display image on touch screen 220, such as a display image of a user interface (UI), and can use touch processor 202 and touch controller 206 to detect a touch on or near touch screen 220, such as a touch input to the displayed UI. The touch input can be used by computer programs stored in program storage 232 to perform actions that can include, but are not limited to, moving an object such as a cursor or pointer, scrolling or panning, adjusting control settings, opening a file or document, viewing a menu, making a selection, executing instructions, operating a peripheral device connected to the host device, answering a telephone call, placing a telephone call, terminating a telephone call, changing the volume or audio settings, storing information related to telephone communications such as addresses, frequently dialed numbers, received calls, missed calls, logging onto a computer or a computer network, permitting authorized individuals access to restricted

areas of the computer or computer network, loading a user profile associated with a user's preferred arrangement of the computer desktop, permitting access to web content, launching a particular program, encrypting or decoding a message, and/or the like. Host processor 228 can also perform additional functions that may not be related to touch processing.

[0031] Note that one or more of the functions described herein can be performed by firmware stored in memory (e.g., one of the peripherals 204 in FIG. 2) and executed by touch processor 202, or stored in program storage 232 and executed by host processor 228. The firmware can also be stored and/or transported within any non-transitory computer-readable storage medium for use by or in connection with an instruction execution system, apparatus, or device, such as a computer-based system, processor-containing system, or other system that can fetch the instructions from the instruction execution system, apparatus, or device and execute the instructions. In the context of this document, a "non-transitory computer-readable storage medium" can be any medium (excluding signals) that can contain or store the program for use by or in connection with the instruction execution system, apparatus, or device. In some examples, RAM 212 or program storage 232 (or both) can be a non-transitory computer readable storage medium. One or both of RAM 212 and program storage 232 can have stored therein instructions, which when executed by touch processor 202 or host processor 228 or both, can cause the device including computing system 200 to perform one or more functions and methods of one or more examples of this disclosure. The computer-readable storage medium can include, but is not limited to, an electronic, magnetic, optical, electromagnetic, infrared, or semiconductor system, apparatus or device, a portable computer diskette (magnetic), a random access memory (RAM) (magnetic), a read-only memory (ROM) (magnetic), an erasable programmable read-only memory (EPROM) (magnetic), a portable optical disc such as a CD, CD-R, CD-RW, DVD, DVD-R, or DVD-RW, or flash memory such as compact flash cards, secured digital cards, USB memory devices, memory sticks, and the like.

[0032] The firmware can also be propagated within any transport medium for use by or in connection with an instruction execution system, apparatus, or device, such as a computer-based system, processor-containing system, or other system that can fetch the instructions from the instruction execution system, apparatus, or device and execute the instructions. In the context of this document, a "transport medium" can be any medium that can communicate, propagate or transport the program for use by or in connection with the instruction execution system, apparatus, or device. The transport medium can include, but is not limited to, an electronic, magnetic, optical, electromagnetic or infrared wired or wireless propagation medium.

[0033] Touch screen 220 can be used to derive touch information at multiple discrete locations of the touch screen, referred to herein as touch nodes. Touch screen 220 can include touch sensing circuitry that can include a capacitive sensing medium having a plurality of drive lines 222 and a plurality of sense lines 223. It should be noted that the term "lines" is sometimes used herein to mean simply conductive pathways, as one skilled in the art will readily understand, and is not limited to elements that are strictly linear, but includes pathways that change direction, and includes pathways of different size, shape, materials, etc.

Drive lines 222 can be driven by stimulation signals 216 from driver logic 214 through a drive interface 224, and resulting sense signals 217 generated in sense lines 223 can be transmitted through a sense interface 225 to sense channels 208 in touch controller 206. In this way, drive lines and sense lines can be part of the touch sensing circuitry that can interact to form capacitive sensing nodes, which can be thought of as touch picture elements (touch pixels) and referred to herein as touch nodes, such as touch nodes 226 and 227. This way of understanding can be particularly useful when touch screen 220 is viewed as capturing an “image” of touch (“touch image”). In other words, after touch controller 206 has determined whether a touch has been detected at each touch nodes in the touch screen, the pattern of touch nodes in the touch screen at which a touch occurred can be thought of as an “image” of touch (e.g., a pattern of fingers touching the touch screen). As used herein, an electrical component “coupled to” or “connected to” another electrical component encompasses a direct or indirect connection providing electrical path for communication or operation between the coupled components. Thus, for example, drive lines 222 may be directly connected to driver logic 214 or indirectly connected to drive logic 214 via drive interface 224 and sense lines 223 may be directly connected to sense channels 208 or indirectly connected to sense channels 208 via sense interface 225. In either case an electrical path for driving and/or sensing the touch nodes can be provided.

[0034] FIG. 3A illustrates an exemplary touch sensor circuit 300 corresponding to a self-capacitance measurement of a touch node electrode 302 and sensing circuit 314 (e.g., corresponding to a sense channel 208) according to examples of the disclosure. Touch node electrode 302 can correspond to a touch electrode 404 or 406 of touch screen 400 or a touch node electrode 408 of touch screen 402. Touch node electrode 302 can have an inherent self-capacitance to ground associated with it, and also an additional self-capacitance to ground that is formed when an object, such as finger 305, is in proximity to or touching the electrode. The total self-capacitance to ground of touch node electrode 302 can be illustrated as capacitance 304. Touch node electrode 302 can be coupled to sensing circuit 314. Sensing circuit 314 can include an operational amplifier 308, feedback resistor 312 and feedback capacitor 310, although other configurations can be employed. For example, feedback resistor 312 can be replaced by a switched capacitor resistor in order to minimize a parasitic capacitance effect that can be caused by a variable feedback resistor. Touch node electrode 302 can be coupled to the inverting input (−) of operational amplifier 308. An AC voltage source 306 (Vac) can be coupled to the non-inverting input (+) of operational amplifier 308. Touch sensor circuit 300 can be configured to sense changes (e.g., increases) in the total self-capacitance 304 of the touch node electrode 302 induced by a finger or object either touching or in proximity to the touch sensor panel. Output 320 can be used by a processor to determine the presence of a proximity or touch event, or the output can be inputted into a discrete logic network to determine the presence of a proximity or touch event.

[0035] FIG. 3B illustrates an exemplary touch sensor circuit 350 corresponding to a mutual-capacitance drive line 322 and sense line 326 and sensing circuit 314 (e.g., corresponding to a sense channel 208) according to

examples of the disclosure. Drive line 322 can be stimulated by stimulation signal 306 (e.g., an AC voltage signal). Stimulation signal 306 can be capacitively coupled to sense line 326 through mutual capacitance 324 between drive line 322 and the sense line. When a finger or object 305 approaches the touch node created by the intersection of drive line 322 and sense line 326, mutual capacitance 324 can change (e.g., decrease). This change in mutual capacitance 324 can be detected to indicate a touch or proximity event at the touch node, as described herein. The sense signal coupled onto sense line 326 can be received by sensing circuit 314. Sensing circuit 314 can include operational amplifier 308 and at least one of a feedback resistor 312 and a feedback capacitor 310. FIG. 3B illustrates a general case in which both resistive and capacitive feedback elements are utilized. The sense signal (referred to as V_{in}) can be inputted into the inverting input of operational amplifier 308, and the non-inverting input of the operational amplifier can be coupled to a reference voltage V_{ref} . Operational amplifier 308 can drive its output to voltage V_o to keep V_{in} substantially equal to V_{ref} , and can therefore maintain V_{in} constant or virtually grounded. A person of skill in the art would understand that in this context, equal can include deviations of up to 15%. Therefore, the gain of sensing circuit 314 can be mostly a function of the ratio of mutual capacitance 324 and the feedback impedance, comprised of resistor 312 and/or capacitor 310. The output of sensing circuit 314 V_o can be filtered and heterodyned or homodyned by being fed into multiplier 328, where V_o can be multiplied with local oscillator 330 to produce V_{detect} . V_{detect} can be inputted into filter 332. One skilled in the art will recognize that the placement of filter 332 can be varied; thus, the filter can be placed after multiplier 328, as illustrated, or two filters can be employed: one before the multiplier and one after the multiplier. In some examples, there can be no filter at all. The direct current (DC) portion of V_{detect} can be used to determine if a touch or proximity event has occurred. Note that while FIGS. 3A-3B indicate the demodulation at multiplier 328 occurs in the analog domain, output V_o may be digitized by an analog-to-digital converter (ADC), and blocks 328, 332 and 330 may be implemented in a digital fashion (e.g., 328 can be a digital demodulator, 332 can be a digital filter, and 330 can be a digital NCO (Numerical Controlled Oscillator)).

[0036] Referring back to FIG. 2, in some examples, touch screen 220 can be an integrated touch screen in which touch sensing circuit elements of the touch sensing system can be integrated into the display pixel stack-ups of a display. The circuit elements in touch screen 220 can include, for example, elements that can exist in LCD or other displays (LED display, OLED display, etc.), such as one or more pixel transistors (e.g., thin film transistors (TFTs)), gate lines, data lines, pixel electrodes and common electrodes. In a given display pixel, a voltage between a pixel electrode and a common electrode can control a luminance of the display pixel. The voltage on the pixel electrode can be supplied by a data line through a pixel transistor, which can be controlled by a gate line. It is noted that circuit elements are not limited to whole circuit components, such as a whole capacitor, a whole transistor, etc., but can include portions of circuitry, such as only one of the two plates of a parallel plate capacitor.

[0037] FIG. 4A illustrates touch screen 400 with touch electrodes 404 and 406 arranged in rows and columns

according to examples of the disclosure. Specifically, touch screen **400** can include a plurality of touch electrodes **404** disposed as rows, and a plurality of touch electrodes **406** disposed as columns. Touch electrodes **404** and touch electrodes **406** can be on the same or different material layers on touch screen **400**, and can intersect with each other, as illustrated in FIG. **4A**. In some examples, the electrodes can be formed on opposite sides of a transparent (partially or fully) substrate and from a transparent (partially or fully) semiconductor material, such as ITO, though other materials are possible. In some examples, the conductive plates can be formed from other materials including conductive polymers, metal mesh, graphene, nanowires (e.g., silver nanowires) or nanotubes (e.g., carbon nanotubes). Electrodes displayed on layers on different sides of the substrate can be referred to herein as a double-sided sensor. In some examples, touch screen **400** can sense the self-capacitance of touch electrodes **404** and **406** to detect touch and/or proximity activity on touch screen **400**, and in some examples, touch screen **400** can sense the mutual capacitance between touch electrodes **404** and **406** to detect touch and/or proximity activity on touch screen **400**.

[0038] FIG. **4B** illustrates touch screen **402** with touch node electrodes **408** arranged in a pixelated touch node electrode configuration according to examples of the disclosure. Specifically, touch screen **402** can include a plurality of individual touch node electrodes **408**, each touch node electrode identifying or representing a unique location on the touch screen at which touch or proximity (i.e., a touch or proximity event) is to be sensed, and each touch node electrode being electrically isolated from the other touch node electrodes in the touch screen/panel, as previously described. Touch node electrodes **408** can be on the same or different material layers on touch screen **402**. In some examples, touch screen **402** can sense the self-capacitance of touch node electrodes **408** to detect touch and/or proximity activity on touch screen **402**, and in some examples, touch screen **402** can sense the mutual capacitance between touch node electrodes **408** to detect touch and/or proximity activity on touch screen **402**.

[0039] FIG. **5A** illustrates an exemplary touch screen that can be used in a touch sensitive device, such as a mobile phone, tablet, touchpad, portable computer, portable media player, wearable device or the like, according to examples of the disclosure. Touch screen **500** can include a stack-up including a display **502**, a polarizer **504**, a touch sensor panel **520** and a cover glass **508** (also referred to as front crystal). Display **502** can generate an image on the touch screen. Polarizer **504** can be used to control the brightness of light emitted from the display **502**. Cover glass **508** can be used as the outermost layer of the touch screen to protect components of the touch screen. Touch sensor panel **520** can be formed from rows and columns of transparent conductive material **512** (touch electrodes) patterned on opposite sides of a dielectric, such as transparent plastic substrate **506**. It should be understood that although the representation of conductive material **512** gives an appearance in a cross-sectional view of FIG. **5A** of electrodes having the same orientation on both sides of substrate **506** (for simplicity of illustration), that the rows and columns on opposite sides of substrate **506** can be perpendicular in a row-column pattern (e.g., as described above with respect to FIG. **4B**). Touch sensor panel **520** can also include passivation layers **516** disposed over the transparent conductive material **512**. The

transparent plastic substrate **506** can act as a dielectric layer between the rows and columns of transparent conducting material **512**. The crossing points between rows and columns of conductive material, separated by the dielectric, can form sensing regions or nodes (e.g., as described above with respect to FIG. **4A**). Although a double-sided row-column pattern is shown in FIG. **5A**, other patterning is possible. For example, the electrodes can be patterned on one side in a row-column pattern using bridges or in a pixelated pattern (e.g., as described above with respect to FIG. **4B**). The transparent plastic substrate can be made from different materials such as cyclo olefin polymer (COP), polyethylene terephthalate (PET), polycarbonate (PC), clear polyimide (CPI) or the like. The transparent conducting material can be indium tin oxide (ITO) or silver nanowire (AgNW), for example. Display **502**, polarizer **504**, touch sensor panel **520** and cover glass **508** can be coupled (e.g., laminated together) by optically clear adhesive (OCA) layers **510**.

[0040] FIG. **5B** illustrates an exemplary polarizer stack-up according to examples of the disclosure. Polarizer **504** can include a polarizing layer, such as a polyvinyl alcohol (PVA) film **530** doped with iodine. Although examples in the disclosure refer to PVA film doped with iodine, it should be understood that polarizing layer is not limited to PVA film doped with iodine, and any suitable polarizing material can be used. The polarizer PVA film **530** can be disposed between substrate layers **532**, **534** to protect the PVA film **530**. The substrate layers can be made from materials including COP, PC, acrylic, triacetyl cellulose (TAC) or the like. Polarizer **504** can also include additional protective layers including a hard coat layer **536** disposed on substrate **532**, and one or more wave plate (retarder) coating layers, such as a half wave plate and/or a quarter wave plate (not shown). The PVA film, the various substrates, protective layers and wave plate layers can be coupled via a lamination process using adhesives (not shown). In some examples, the PVA film **530** can be 5-35 μm and the substrate layers can be between 15-50 μm .

[0041] Referring back to FIG. **5A**, in some examples, the touch electrodes (conductive material **512**) can be routed to touch sensing circuitry (e.g., touch controller **206**) outside the visible area of the touch screen (e.g., disposed beneath display **502**). For example, FIG. **5A** illustrates a flexible printed circuit (FPC) **550** (also referred to herein as “flex circuit”) that can be coupled to touch sensor panel **520**. In some examples, the coupling can be via a bonding pad or conductive film **514** (e.g., anisotropic conductive film (ACF)). As shown in FIG. **5A** the flex circuit **550** can include one or multiple tabs to couple to one or more different sides of the touch sensor panel **520**. The number of tabs can depend on the pattern of conductive material forming the touch electrodes and on the routing of the touch electrodes to the edges of substrate **506**. In some examples, the touch electrodes on one side of substrate **506** (e.g., rows) can be routed to one side of the touch sensor panel and touch electrodes on another side of substrate **506** (e.g., columns) can be routed to a different side of the touch sensor panel. In such an example, two flex circuit tabs may be used. In some examples, more or fewer flex circuits may be used.

[0042] The flex circuit **550** connection to touch sensor panel **520**, however, can increase the thickness of touch screen stack-up **500**. Additionally, connecting the flex circuit **550** to touch sensor panel **520** can require a border region around the active touch and display region of the touch

screen that may not be used for display and/or touch sensing. In some examples, as described herein, the thickness of the touch screen stack-up can be reduced and/or the border region reduced, by removing the flex circuit from the stack-up. Instead, in some examples, the touch sensor panel can be formed using a flexible substrate (e.g., replacing a single-layer rigid substrate in the stack-up with a flexible substrate). The touch electrodes can be routed from the touch sensor panel to the touch sensing circuitry using the flexible substrate rather than a flexible printed circuit. Reducing the thickness of the touch screen can provide for a lower profile device and can reduce the weight of the device. Additionally, reducing the display to cover glass distance can improve the optical image on the display and/or can reduce mechanical strain during bending of the touch screen.

[0043] Although not illustrated in FIG. 5A, in some examples, a touch screen stack-up can include a shield layer between the touch sensor panel and the display to reduce interference between the touch and display systems. In some examples, routing the shield layer can also require a flex circuit (or another tab of an existing flex circuit). In some examples, as described herein, the thickness of the touch screen stack-up including a shield layer can be reduced by routing the shield layer to a shield electrode on the touch sensor panel. The shield layer (via the shield electrode) can then be routed to touch sensing circuitry (e.g., touch controller 206) via the flexible substrate of the touch sensor panel.

[0044] Additionally or alternatively, in some examples, as described herein, the touch sensor panel 520 or a portion thereof can be integrated with polarizer 504. Integrating the touch sensor panel 520 with the polarizer 504 can reduce the thickness of the touch screen stack-up because one substrate can be used in place of transparent plastic substrate 506 of the touch sensor panel and substrate 532 of the polarizer. Reducing the thickness of the touch screen also provides the added benefit of reducing the weight of the device. Additionally, reducing the display to cover glass distance can improve the optical image on the display and/or can reduce mechanical strain during bending of the touch screen.

[0045] FIGS. 6A-6D illustrate examples of touch screen stack-ups with a flexible substrate according to examples of the disclosure. In some examples, as shown in FIGS. 6A-6C, the stack-up can include a flexible substrate configured to flex from the touch sensor panel around to an opposite side of the display (wrap-around). In some examples, the stack-up may not include a full wrap-around, but may include a flexible substrate which extends, at least partially, beyond the visual area of the touch screen (beyond the display/touch electrode area of the stack-up). For example, FIG. 6D shows a short tab extending from the stack-up for connection to a flex circuit. The latter implementation can remove the flex circuit from the stack-up (thereby reducing the height of the stack-up) without requiring as much flexibility from the substrate as a full wrap-around shown in FIGS. 6A-6C.

[0046] FIG. 6A illustrates touch screen 600 can include a display 602, a polarizer 604, a touch sensor panel 620 (e.g., including touch electrodes 612, passivation layers 616 disposed on substrate 606), a cover glass 608 and one or more adhesive layers 610. Touch screen 600 can be similar to touch screen 500, and some differences will be described below for ease of description. Unlike FIG. 5A with a rigid/planar substrate 606 in the stack-up and a flex circuit

550 to connect touch sensor panel 520 with touch sensing circuitry, touch sensor panel 620 can connect with touch sensing circuitry without including a flex circuit connection in the stack-up. Instead, touch sensor panel 620 of touch screen 600 can include a substrate 606 formed with a flexible material. A portion of the substrate within the stack-up (labeled 606A in FIG. 6B) can be planar due to its placement within the stack-up (which may include other rigid layers). A portion of the substrate outside of the stack-up (labeled 606B in FIG. 6B) can be non-planar and flexible to bend from the touch sensor panel 620 to below the display 602. In some examples, a portion of the substrate (labeled 606C in FIG. 6B) can be planar due to its placement below display 602. The flexible substrate 606 can route the touch electrodes of touch screen 620 to touch sensing circuitry below display 602 (e.g., on a printed circuit board (PCB) 648). Although FIG. 6A shows the polarizer below the touch sensor panel, in some examples, the polarizer can be disposed above the touch sensor panel.

[0047] FIG. 6B illustrates additional details of the example of the wrap-around flexible substrate of touch screen 600 of FIG. 6A. The substrate illustrated in FIG. 6B can be formed of a flexible material such as CPI, COP (e.g., partially crystallized and partially amorphous), or PET. The flexibility provided by flexible materials can enable bending of the substrate (e.g., portion 606B of the substrate). In some examples, as shown in FIGS. 6A-6B, for example, the bending of portion 606B of the substrate can provide for 180 degrees of bending between substantially planar portions 606A and 606C of the substrate. The planar portion 606A can include touch electrodes 612 of the touch sensor panel and can be disposed above the display of the touch screen. The planar portion 606A can also include a passivation layer 662 (e.g., corresponding to passivation layer 616) above touch electrodes 612. In some examples, to reduce the stack-up thickness, passivation layer 662 can be formed using a material with both adhesive and passivation properties such that the stack-up does not need to include both the adhesive layer above the touch sensor panel (e.g., corresponding to adhesive layer 610) and a separate passivation layer (e.g., corresponding to passivation layer 616). The planar portion 606C can be disposed below the display of the touch screen (outside the visible area). In some examples, the substrate can include a protective coating (e.g., hard coating 660) which can improve performance for bending of the substrate. In some examples, hard coating 660 may be replaced (or augmented) with a coating layer (not necessarily hard) to provide for improved adhesion and/or for chemical compatibility for deposition of touch electrodes.

[0048] As described above with respect to FIG. 6A, the flexible substrate 606 can route the touch electrodes of touch screen 620 to touch sensing circuitry below display 602. For example, the flexible substrate can include routing 644 to route touch electrodes 612 from the touch sensor panel 620 to the touch sensing circuitry. As shown in FIG. 6B, the routing 644 can be flexible and can be disposed on portion 606B of the substrate. The routing 644 can be electrically coupled to touch electrodes 612 at a first interconnection interface (e.g., on portion 606A of the substrate). The routing 644 can be electrically coupled to the touch sensing circuitry (not shown) via a second interconnection interface (e.g., on portion 606C of the substrate). Additionally, a protective

coating **642** can be included to prevent corrosion and/or to provide mechanical stability for routing **644** and the flexible substrate **606**.

[0049] For ease of description, FIG. 6B illustrates touch electrodes **612** on one side of substrate **606A**, but it is understood that for double-sided touch sensor panels (e.g., such as the double-sided touch sensor panel **620** in FIG. 6A), additional touch electrodes **612** can be disposed and routed via the flexible substrate. For example, touch electrodes **612** on the opposite side of the flexible substrate (shown in FIG. 6A, but not shown in FIG. 6B) can be routed from portion **606A** to **606B** to **606C** of the substrate (e.g., along the inner portion of the flexible substrate in portion **606B** shown in FIG. 6B). In some examples, the touch electrodes **612**, hard coating **660**, routing trace **644** and/or protective layer **642** can be mirrored on the second side of substrate **606** for such a stack-up.

[0050] In some examples, the touch electrodes on the second, opposite side of the substrate can be routed via a wrap-around bend at another edge of the touch sensor panel. For example, FIG. 6C illustrates additional details of an example of the flexible substrate of touch screen **600** of FIG. 6A including a double-sided touch sensor panel and wrapping around multiple different edges of the touch sensor panel. The substrate of FIG. 6C can be formed of a flexible material such as CPI, COP, or PET. The flexibility provided by flexible materials can enable bending of the substrate (e.g., portions **606B/606B'** of the substrate). In some examples, as shown in FIG. 6C, for example, the bending of portion **606B** on a first side of the substrate can provide for 180 degrees of bending between substantially planar portions **606A** and **606C** of the substrate, and the bending of portion **606B'** on a second side of the substrate (different from the first side of the substrate) can be provide for 180 degrees of bending between substantially planar portions **606A** and **606C** of the substrate. In some examples, the first side and the second side of the substrate at which bending occurs can be on opposite sides as illustrated in FIG. 6C (for simplicity of illustration). In some examples, the first side and the second side of the substrate at which bending occurs can be on adjacent sides. Although bending is illustrated at two sides of the substrate in FIG. 6C, it should be understood that the bending can occur at fewer or more sides of the substrate. Additionally, the bending described herein can occur along the entire side of the substrate (e.g., to reduce the border region around the touch screen) or only for a portion of the substrate (e.g., to reduce the border region proximate to another component (e.g., a camera or other sensor or circuitry)).

[0051] The planar portion **606A** can include touch electrodes **612** of the touch sensor panel and can be disposed above the display of the touch screen (e.g., the touch electrodes and/or planar portion **606A** can be coterminous with the display). In double-sided touch sensor panels, the touch electrodes **612** can include electrodes on opposite sides of the substrate (e.g., in a row-column pattern, as described with respect to FIG. 6A). In some examples, the substrate can include a protective coating (e.g., hard coating **660**) which can improve performance for bending of the substrate. In some examples, hard coating **660** may be replaced (or augmented) with a coating layer (not necessarily hard) to provide for improved adhesion and/or for chemical compatibility for deposition of touch electrodes. The planar portion **606A** can also include one or more layers

above touch electrodes **612** (e.g., on both sides of the substrate). In some examples, the one or more layers can include a passivation layer (e.g., corresponding to passivation layer **616**) and adhesive layer (e.g., corresponding to adhesive layer **610**) over touch electrodes **612** on both sides of the substrate. In some examples, to reduce the stack-up thickness, protective/adhesive layer **672** can be formed using a material with both adhesive and passivation properties such that the stack-up does not need to include both the adhesive layer (e.g., corresponding to adhesive layer **610**) and a separate passivation layer (e.g., corresponding to passivation layer **616**). The planar portion **606C** can be disposed below the display of the touch screen (outside the visible area).

[0052] The flexible substrate can route the touch electrodes **612** of touch screen **600** to touch sensing circuitry below display **602**. For example, the flexible substrate can include routing **644** on a first side of the flexible substrate to route touch electrodes **612** from one side of the touch sensor panel **620** to the touch sensing circuitry. Likewise, the flexible substrate can include routing **644'** on a second side of the flexible substrate to route touch electrodes **612** from the second, opposite side of the touch sensor panel **620** to the touch sensing circuitry. As shown in FIG. 6C, the routing **644**, **644'** can be flexible and can be disposed on portions **606B**, **606B'** of the substrate. The routing **644**, **644'** can be electrically coupled to touch electrodes **612** at first interconnection interfaces (e.g., on two ends of portion **606A** of the substrate). The routing **644**, **644'** can be electrically coupled to the touch sensing circuitry (not shown) via second interconnection interfaces (e.g., on portions **606C**, **606C'** of the substrate). In some examples, protective/adhesive layer **672** can extend from portion **606A** to portions **606B**, **606B'**, **606C**, **606C'** to provide protection from corrosion and/or provide mechanical stability for routing **644**, **644'** and the flexible substrate **606**. In some examples, a separate protective coating (e.g., corresponding to protective coating **642** in FIG. 6B) can be included to prevent corrosion and/or to provide mechanical stability for routing **644**, **644'** and the flexible substrate **606**.

[0053] As discussed above, the routing in the flexed portion **606B** (bending area of portion **606B**) of the substrate can be flexible for reliability. FIGS. 7A-7J illustrate examples of flexible substrates and routing according to examples of the disclosure. FIGS. 7A-7J illustrate a planar substrate **706** prior to bending. For simplicity of illustration and description, routing of one touch electrode (e.g., touch electrode **712**) is shown, but it is understood that routing can be included for additional touch electrodes. FIG. 7A illustrates an example with touch electrodes **712** formed from ITO and with copper terminated ITO routing forming an extended bond pad across substrate **706** (from portion **706A** to **706C**) for an interconnect to touch sensing circuitry via the copper terminated bond pad. The touch electrode **712** can be connected the copper terminated ITO in portion **706A** by a routing trace formed of ITO, for example.

[0054] In some examples, the flexibility of routing can be improved by selecting materials with improved flexibility compared with ITO. For example, the copper terminated ITO in the bending area of portion **706B** can be replaced with a flexible conductor, such as a silver (or copper) paste. FIG. 7B illustrates an example with a copper terminated ITO bond pad in portion **706C** (and a copper terminated ITO bond pad in portion **706A** that can be coupled to touch

electrodes **712** in portion **706A** by a routing trace formed of ITO, for example), but without the ITO (and copper) in the bending area of portion **706B**. Instead, a silver paste can be used for routing in portion **706B**. In some examples, copper can be omitted from the bond pads as well. For example, FIG. **7C** illustrates an example with ITO bond pads without copper termination. In some examples, for example as illustrated in FIG. **7D**, the silver paste can form the bond pads (without ITO and/or copper).

[0055] In some examples, as illustrated in FIG. **7E**, rather than using a silver (or copper) paste, the routing from the touch electrodes **712** can be via sputtered copper or silver across substrate **706** (from portion **706A** to **706C**) for an interconnect to touch sensing circuitry via the sputtered copper or silver bond pad. In a similar manner as described above with respect to FIGS. **7A-7B**, the touch electrode **712** formed of ITO can be connected the ITO in portion **706A** by a routing trace formed of ITO, for example, in FIGS. **7C-7E**.

[0056] Although FIGS. **7A-7E** refer to touch electrodes **712** formed from ITO, it should be understood that touch electrodes can be formed from other materials (e.g., silver nanowire). For example, FIGS. **7F-7J** illustrate a flexible substrate **706** that can include touch electrodes **712** that can be formed of silver nanowire. The touch electrode **712** represented in FIGS. **7F-7J** can be connected to the silver nanowire material in portion **706A** by a routing trace formed of silver nanowire, for example. In some examples, the silver nanowire touch electrodes can be routed via silver (or copper) paste (e.g., as described with respect to FIG. **7D**). In some examples, the silver nanowire touch electrodes can be routed via copper or silver traces (e.g. sputtered silver or copper, or printed silver ink), as illustrated in FIG. **7F**. The copper or silver can form the bond pads for interconnection in portion **706C**. In some examples, silver nanowire can be used in portion **706B** for flexible routing, as shown in FIG. **7G**. Additionally or alternatively, as shown in FIG. **7G**, the bond pad for interconnection in portion **706C** can be formed of copper or a silver paste (or ink). In some examples, the silver nanowire in portions **706A-706C** can be overlaid with silver paste or ink, as illustrated, for example in FIG. **7H** (e.g., to improve the conductivity of the routing).

[0057] In some examples, the routing in the bending area (portion **706B**) can be silver (or copper) paste or ink (or other sputtered silver or copper), as illustrated in FIG. **7I**. Thus, FIG. **7I** can be similar to FIGS. **7D-7E**, but using a silver nanowire touch electrode rather than an ITO touch electrode. In some examples, the routing can be formed of both silver nanowire and silver paste (or ink or sputtered silver or copper) in portions **706A-706C**, with the silver nanowire overlaying silver paste or ink as illustrated, for example, in FIG. **7J** (as opposed to silver nanowire overlaid with silver paste or ink as in FIG. **7H**).

[0058] It should be understood that FIGS. **7A-7J** illustrate exemplary options for routing for a flexible substrate (and for touch electrodes and bond pads), but other materials and options can be implemented for flexible routing between the touch electrodes and touch sensing circuitry.

[0059] As described above, in some examples, the flexible substrate may not fully wrap-around from the touch sensor panel to touch sensing circuitry (e.g., disposed behind the display). In some examples, the touch screen may include a flexible substrate which extends, at least partially, beyond the visual area of the touch screen. For example, FIG. **6D** shows a short flexible tab extending from the stack-up for

connection to a flex circuit (and subsequently to the touch sensing circuitry, not shown). FIG. **6D** illustrates touch screen **630** that can be similar to touch screen **600** of FIG. **6A**, and some differences will be described below for ease of description. Unlike FIG. **6A** with a flexible substrate **606** wrapping around from the touch sensor panel **620** to behind the display **602**, in FIG. **6D** the flexible substrate **606** can include a tab **606D** extending from the stack-up and a flex circuit **650** coupled to tab **606D** to route the touch electrodes **612** of touch sensor panel **620** to touch sensing circuitry. Connecting the flex circuit **650** to tab **606D** outside of the stack-up can reduce the height of the stack-up relative to FIG. **5A** where the flexible circuit is coupled within the stack-up. Although FIG. **6D** shows one short flexible tab and one flex circuit, it should be understood that additional flexible tabs (and corresponding flex circuits) can be implemented on additional side of the substrate, in some examples.

[0060] Although primarily illustrated in FIG. **6A-6D** as a planar touch screen, it should be understood that the flexible substrate described herein can also include touch electrodes and other flexible circuitry to enable curved, flexible or foldable touch sensors.

[0061] As mentioned above, in some examples, a touch screen stack-up can include a shield layer between the touch sensor panel and the display to reduce interference between the touch and display systems. The thickness of the touch screen stack-up including a shield layer can be reduced by routing the shield layer to a shield electrode on the touch sensor panel. The shield layer can then be routed to touch sensing circuitry (e.g., touch controller **206**) via the flexible substrate. In some examples that use flex circuits rather than a flexible substrate, routing the shield layer to the touch sensing layer can reduce the number of flex circuits (or tabs), which can reduce the thickness of the stack-up.

[0062] FIGS. **8A-8B** illustrate an example of touch screen stack-up with a shield layer routed to the touch sensor panel examples of the disclosure. FIG. **8A** illustrates touch screen **800** can include a display **802**, a polarizer **804**, a touch sensor panel **820** (e.g., including touch electrodes **812** patterned on one side of substrate **806**, passivation/adhesive layer **816** disposed on substrate **806**), a cover glass **608** and one or more adhesive layers **810**. Touch screen **800** can be similar to touch screen **600**, and some differences will be described below for ease of description. Unlike FIG. **6A**, touch screen **800** can include a shield layer **870** between its touch sensor panel **820** (illustrated as a single-sided touch electrode pattern) and display **802** (and/or polarizer **804**). In some examples, shield layer **870** can be formed of a partially or fully transparent material such as ITO, silver nanowire, etc. The shield layer **870** can reduce interference between the touch sensor panel **820** and the display **802**.

[0063] The shield layer **870** can be separated from the touch electrodes **812** by at least substrate **806**, such that the touch electrodes **812** can be disposed on a first side of substrate **806** and shield layer **870** can be disposed on a second side, opposite the first side. In some examples, the shield layer can be formed on the substrate **806** (on the second side for a one-sided touch electrode pattern). In some examples, the shield layer can be formed on a different substrate in the stack-up than substrate **806** upon which the touch electrodes **812** are formed. In such examples, the shield layer **870** can be further separated from touch sensor panel **820** by an adhesive layer. In some examples, the

different substrate can be a substrate of polarizer **804**. Using a substrate of polarizer **804** can reduce the thickness of the stack-up.

[0064] Touch screen **800** also includes a conductive bridge **880** to electrically couple the shield layer **870** from the second side of substrate **806** to the first side of substrate **806** of touch sensor panel **820**. For example, a silver (or copper) paste can wrap around substrate **806** to the side of the substrate including the touch electrodes. It is understood that other suitable materials (e.g., conductive films, etc.) can be used to form a bridge between the shield layer **870** and the touch sensor panel **820**. The conductive bridge **880** can connect to an electrode (“shield electrode”) **882** on the first side of substrate **806** of touch sensor panel **820**. In some examples, shield electrode **882** can be formed of ITO, though other materials are possible (e.g., silver nanowire, etc.). The shield electrode **882** can then be routed to touch sensing circuitry (e.g., to drive the shield with a voltage, such as the touch sensing stimulation voltage). For example, as shown in FIG. **8A**, the wraparound of conductive bridge **880** can wrap around the edge of substrate **806**, opposite the edge of the stack-up from which flexible substrate **806** extends. The shield layer **870**, via conductive bridge **880** and shield electrode **882**, can therefore be routed to the touch sensing circuitry via the flexible substrate to the touch sensing circuitry (e.g., on PCB **848**). In some examples, the conductive bridge can be used in a stack-up that does not include a flexible substrate. Instead, the shield electrode can be routed to touch sensing circuitry via a flex circuit. Whether a flexible substrate or flex circuit is used, the conductive bridge **880** can reduce the thickness of the stack-up because a separate flex circuit does not need to be used to connect the shield layer to the touch sensing circuitry.

[0065] FIG. **8B** illustrates another view of touch screen **800** including some additional details according to examples of the disclosure. For example, FIG. **8B** illustrates additional details regarding the flexible substrate **806** of touch sensor panel **820** to enable connection of touch sensor panel **820** to touch sensing circuitry (not shown) without a flex connector. The planar portion of substrate **806** can include touch electrodes **812**. The planar portion of substrate **806** can also include a passivation layer **817** (with separate adhesive layer **810**, together corresponding to passivation/adhesive layer **816**) above touch electrodes **612**. In some examples, the substrate can include a protective coating (e.g., hard coating **860**) which can improve performance for bending of the substrate. In some examples, hard coating **860** may be replaced (or augmented) with a coating layer (not necessarily hard) to provide for improved adhesion and/or for chemical compatibility for deposition of touch electrodes. An index matching layer can be disposed between hard coating **860** and conductive layers (e.g., touch electrodes **812**, shield layer **870**, shield electrode **882**) for matching optical properties (e.g., to reduce the index of refraction change between two materials with different indexes of refraction). The flexible substrate **806** can also include routing **844** to route touch electrodes **812** from the touch sensor panel **820** to the touch sensing circuitry. Additionally, a protective coating **842** can be included to prevent corrosion and/or to provide mechanical stability for routing **844** and the flexible substrate **806**.

[0066] Conductive bridge **880** can be coupled to shield layer **870** and shield electrode **882** as illustrated by inter-

connections. For example, on the side of the stack-up including conductive bridge **880**, display **802**, polarizer **804** and shield layer **882** can be wider than touch sensor panel **820** to enable the conductive bridge **880** to be bonded to shield layer **870** (e.g., within the stack-up). Conductive bridge **880** can then wrap around substrate **806** to a bond pad corresponding to shield electrode **882** on the opposite side of substrate **806** from shield layer **870**.

[0067] Although FIGS. **8A-8B** illustrate shield layer **870** disposed on top of polarizer **804**, in some examples, the shield layer **870** can be disposed on a different layer of polarizer **804**. For example, the shield layer could be disposed on the opposite side of polarizer **804** (e.g., between polarizer **804** and display **802**). In such a case, the polarizer can be narrowed within the stack-up to enable conductive bridge **880** to be bonded to shield layer **870**. In some examples, shield layer **870** can be disposed on display **802** and coupled to driving circuitry via a flex circuit for display **802** (not shown).

[0068] Additionally, or alternatively, in some examples, as described herein, the touch sensor panel or a portion of thereof can be integrated with polarizer. Integrating the touch sensor panel with the polarizer can reduce the thickness of the touch screen stack-up because fewer substrates can be used.

[0069] FIGS. **9** and **10** illustrate examples of an integrated touch sensor panel and polarizer according to examples of the disclosure. FIG. **9** illustrates an integrated touch sensor panel and polarizer **900** in which a double-sided touch sensor panel **910** is formed using the polarizer substrate according to examples of the disclosure. An example polarizer (e.g., corresponding to polarizer **504** from FIG. **5B**) without an integrated touch sensor panel is reproduced on the left-hand side of FIG. **9**, which includes a substrate (labeled “COP”). In some examples, the same substrate can be shared by the touch sensor panel **910** and the polarizer layers for an integrated touch sensor panel and polarizer **900**. For example, as illustrated in FIG. **9**, prior to forming the polarizer layers (e.g., PVA film, TAC, etc.) on the substrate, touch electrodes **904** can be disposed on both sides of substrate **902**. Although touch electrodes **904** are shown on both sides of substrate **902**, it should be understood that in some examples the touch electrodes can be disposed on one side of the substrate (e.g., for a pixelated touch electrode pattern shown in FIG. **4B** or a single-sided row-column touch electrode pattern using bridges). Touch electrodes **904** can be formed from ITO, or other suitable materials (e.g., silver nanowire, etc.). A passivation layer **906** can be disposed on touch electrodes **904**. Forming the touch electrodes on the substrate prior to forming the polarizer layers can enable high-temperature processing steps for touch electrodes (e.g., for ITO deposition and annealing) that may damage polarizer layers. After forming sensor panel **910**, the remaining polarizer layers (e.g., hard coat, PVA film, TAC layer, etc.) can be formed on touch sensor panel **910** to form integrated touch sensor panel and polarizer **900**.

[0070] FIG. **10** illustrates an integrated touch sensor panel and polarizer **1000** in which a single-sided touch sensor panel **1010** is formed using the polarizer substrate according to examples of the disclosure. An example polarizer (e.g., corresponding to polarizer **504** from FIG. **5B**) without an integrated touch sensor panel is reproduced on the left-hand side of FIG. **10**, which includes a substrate (labeled “COP”). In some examples, the same substrate can be shared by the

touch sensor panel **1010** and the polarizer layers for an integrated touch sensor panel and polarizer **1000**. For example, as illustrated in FIG. **10**, before or after forming the polarizer layers (e.g., PVA film, TAC, etc.) on the substrate, touch electrodes **1004** can be disposed on the hard coat layer **1008** on substrate **1002**. Touch electrodes **1004** can be formed from ITO, or other suitable materials (e.g., silver nanowire, etc.). Although not shown in FIG. **10**, in some examples, a passivation layer can be disposed on touch electrodes **1004**.

[**0071**] Additionally, in some examples, integrated touch sensor panel and polarizer **1000** can include a shield layer **1022**. The shield layer can be formed of ITO or other suitable materials (e.g., silver nanowire), and can be formed on a second substrate **1020**, which can serve as the bottom substrate of integrated touch sensor panel and polarizer **1000**. In some examples, a passivation layer **1024** can be disposed on shield layer **1022**. In some examples, the shield layer **1022** can be coupled to the layer including touch electrodes **1004** via a conductive bridge (e.g., as described above with respect to shield layer **870**, conductive bridge **880**, and shield electrode **882**). Substrate **1020**, shield layer **1022** and passivation layer **1024** can be coupled (e.g., via adhesive, lamination) to the rest of integrated touch sensor panel and polarizer **1000**.

[**0072**] In some examples, forming the touch electrodes on the substrate/hard coat prior to forming the polarizer layers can enable high-temperature processing steps for touch electrodes (e.g., for ITO deposition and annealing) that may damage polarizer layers. After forming sensor panel **1010**, the remaining polarizer layers (e.g., PVA film, TAC layer, etc.) can be formed on touch sensor panel **1010** to form integrated touch sensor panel and polarizer **1000**. In some examples, the touch electrodes can be formed on the substrate/hard coat after forming the polarizer layers using lower-temperature processing steps for touch electrodes (e.g., silver nanowire) that may be performed without damaging polarizer layers.

[**0073**] FIG. **11** illustrates an exemplary process **1100** for forming an integrated touch sensor panel and polarizer according to examples of the disclosure. At **1105**, a first substrate can be formed. The first substrate can be formed from a glass or a transparent polymer (e.g., COP). At **1110**, a touch sensor panel can be formed on the substrate. For example, as described above with respect to FIG. **9**, touch electrodes can be deposited on one or both sides of the substrate to form the touch sensor panel **910**. In some examples, the touch electrodes can be formed of ITO via deposition and annealing. Additionally, in some examples, a passivation layer can be deposited over the touch electrodes to protect the touch electrodes and/or to planarize the touch sensor panel. At **1115**, the polarizer layers can be formed on the touch sensor panel. For example, the polarizer layers can include, as described herein, one or more hard coat layers, one or more adhesive layers, one or more optical retarder layers (e.g., HWP, QWP), a polyvinyl alcohol layer (e.g., PVA film layer), and a tri-acetyl cellulose layer. In some examples, the integrated touch sensor panel and polarizer can include a shield layer to reduce interference between the touch sensor panel and the display. For example, at **1120**, the shield layer can be formed on a second substrate. The shield layer can be formed of ITO or other suitable materials (e.g., silver nanowire). A passivation layer can be disposed on the shield layer as well. At **1125**, the second substrate (and the

shield layer) can be coupled to the polarizer layers (e.g., via an adhesive layer and lamination process).

[**0074**] It should be understood that FIG. **11** describes an example process for forming an integrated touch sensor panel and polarizer according to examples of the disclosure. For example, the integrated touch sensor panel and polarizer of FIG. **11** can be formed without the shield layer (omitting **1120** and **1125**). In some examples, touch electrodes can be formed on one side of the substrate at **1110**, and additional touch electrodes can be formed on one side of a second substrate. The second substrate and touch electrodes can be coupled instead of the shield layer at **1125**. In some examples, the touch sensor panel may include touch electrodes formed on only one side (e.g., pixelated touch electrodes). In such examples, the touch electrodes can be formed on the hard coat of the substrate. In some examples, the polarizer can first be formed on the substrate and subsequently the touch electrodes can be formed on the polarizer (e.g., as described above with respect to FIG. **10**).

[**0075**] Therefore, according to the above, some examples of the disclosure are directed to a touch screen comprising: a display and a touch sensor panel disposed on the display. The touch sensor panel can comprise a substrate formed from a flexible material and touch electrodes formed on one or more surfaces of the substrate. A first portion of the substrate including the touch electrodes can be planar and a second portion of the substrate can be non-planar such that the substrate extends beyond a dimension of the display. Additionally or alternatively to one or more of the examples disclosed above, in some examples, the second portion of the substrate can be a tab. Additionally or alternatively to one or more of the examples disclosed above, in some examples, the second portion of the substrate can wrap around from the touch sensor panel to a different layer in the touch screen. The different layer can be separated from the touch sensor panel by the display. Additionally or alternatively to one or more of the examples disclosed above, in some examples, the touch screen can further comprise a flex circuit coupled to the second portion of the substrate outside the dimensions of the display. Additionally or alternatively to one or more of the examples disclosed above, in some examples, the touch screen can further comprise conductive traces disposed on the second portion of the substrate configured to route the touch electrodes disposed on the first portion of the substrate to touch sensing circuitry. Additionally or alternatively to one or more of the examples disclosed above, in some examples, the conductive traces disposed on the second portion of the substrate can comprise first conductive traces disposed on a first side of the substrate in the second portion of the substrate and second conductive traces disposed on a second side of the substrate in the second portion of the substrate. Additionally or alternatively to one or more of the examples disclosed above, in some examples, the first conductive traces can be disposed between an inner coating layer disposed on the first side of the substrate and an outer coating layer disposed over the first conductive traces. Additionally or alternatively to one or more of the examples disclosed above, in some examples, the second conductive traces can be disposed between an inner coating layer disposed on the second side of the substrate and an outer coating layer disposed over the second conductive traces. Additionally or alternatively to one or more of the examples disclosed above, in some examples, the touch electrodes can be formed from indium tin oxide and the

conductive traces disposed on the second portion of the substrate can be formed without indium tin oxide. Additionally or alternatively to one or more of the examples disclosed above, in some examples, the touch electrodes can be formed from silver nanowire and the conductive traces disposed on the second portion of the substrate can be formed from silver nanowire. Additionally or alternatively to one or more of the examples disclosed above, in some examples, the first portion of the substrate can be coterminous with the display. Additionally or alternatively to one or more of the examples disclosed above, in some examples, a third portion of the substrate can be planar and separated from the first portion of the substrate by the display. Additionally or alternatively to one or more of the examples disclosed above, in some examples, the touch screen can further comprise a bonding pad disposed on the third portion of the substrate. Additionally or alternatively to one or more of the examples disclosed above, in some examples, the touch screen can further comprise a coating layer disposed on the one or more surfaces of the substrate. The touch electrodes formed on the one or more surfaces of the substrate can be disposed on the coating layer. Additionally or alternatively to one or more of the examples disclosed above, in some examples, the touch screen can further comprise a protective layer disposed on the one or more surfaces of the substrate. The touch electrodes can be formed on the one or more surfaces of the substrate can be disposed on the protective layer. Additionally or alternatively to one or more of the examples disclosed above, in some examples, the second portion of the substrate can be separated from the display such that a gap can be formed between the second portion of the substrate and the display. Additionally or alternatively to one or more of the examples disclosed above, in some examples, the substrate can wrap around from the touch sensor panel to a different layer in the touch screen on a first side of the touch screen without the substrate wrapping around to the different layer in the touch screen on a second side of the touch screen different than the first side of the touch screen. Additionally or alternatively to one or more of the examples disclosed above, in some examples, a fourth portion of the substrate (e.g., 606B') can be non-planar such that the substrate can extend beyond a second dimension of the display different than the first dimension of the display. Additionally or alternatively to one or more of the examples disclosed above, in some examples, the fourth portion of the substrate can wrap around from the touch sensor panel to the different layer in the touch screen. Additionally or alternatively to one or more of the examples disclosed above, in some examples, the touch screen can further comprise first conductive traces disposed on a first side of the substrate in the second portion of the substrate and second conductive traces disposed on a second side of the substrate opposite the first side of the substrate in the fourth portion of the substrate. Additionally or alternatively to one or more of the examples disclosed above, in some examples, the first conductive traces can be configured to route first touch electrodes of the touch electrodes on a first side of the substrate to touch sensing circuitry and the second conductive traces can be configured to route second touch electrodes of the touch electrodes on a second side of the substrate to the touch sensing circuitry.

[0076] Some examples of the disclosure are directed to a touch screen comprising a touch sensor panel, a shield layer and conductive routing. The touch sensor panel can com-

prise a first substrate and touch electrodes formed on a first surface of the first substrate. The first substrate can separate the touch electrodes from the shield layer. The conductive routing can be configured to route the shield layer around a first edge of the first substrate to the first side of the first substrate. Additionally or alternatively to one or more of the examples disclosed above, in some examples, the shield layer can be disposed on a second substrate different from the first substrate. Additionally or alternatively to one or more of the examples disclosed above, in some examples, the touch screen can further comprise a polarizer comprising the second substrate. Additionally or alternatively to one or more of the examples disclosed above, in some examples, the polarizer can further comprise the first substrate. Additionally or alternatively to one or more of the examples disclosed above, in some examples, the touch screen can further comprise an adhesive layer disposed between the touch sensor panel and the shield layer. Additionally or alternatively to one or more of the examples disclosed above, in some examples, the touch screen can further comprise an index matching layer disposed between the touch sensor panel and the shield layer. Additionally or alternatively to one or more of the examples disclosed above, in some examples, the shield layer can be disposed on a second side of the first substrate. Additionally or alternatively to one or more of the examples disclosed above, in some examples, the shield layer can comprise indium tin oxide or silver nanowire. Additionally or alternatively to one or more of the examples disclosed above, in some examples, the conductive routing can comprise silver paste. Additionally or alternatively to one or more of the examples disclosed above, in some examples, the touch sensor panel can further comprise: a shield electrode on the first side of the first substrate separate from the touch electrodes. The conductive routing can electrically couple the shield layer to the electrode on the first side of the first substrate. Additionally or alternatively to one or more of the examples disclosed above, in some examples, the shield electrode can comprise indium tin oxide or silver nanowire. Additionally or alternatively to one or more of the examples disclosed above, in some examples, the touch screen can further comprise a flexible connector disposed on a second edge of the first substrate. The flexible connector can be configured to route the touch electrodes and the shield layer from the first side of the first substrate to touch sensing circuitry. Additionally or alternatively to one or more of the examples disclosed above, in some examples, the shield layer can extend beyond the first edge of the first substrate such that the conductive routing can be disposed on the shield layer without extending beyond a length of a display of the touch screen.

[0077] Some examples of the disclosure are directed to a touch screen. The touch screen can be prepared by a process comprising: forming a substrate; forming a touch sensor panel on the substrate; and forming polarizer layers on the touch sensor panel. Additionally or alternatively to one or more of the examples disclosed above, in some examples, the substrate can have a thickness less than 50 μm . Additionally or alternatively to one or more of the examples disclosed above, in some examples, forming the touch sensor panel on the substrate can comprise depositing touch electrodes on both sides of the substrate. Additionally or alternatively to one or more of the examples disclosed above, in some examples, forming the touch sensor panel on the substrate can comprise depositing a passivation layer

over the touch electrodes. Additionally or alternatively to one or more of the examples disclosed above, in some examples, the substrate can be formed from a transparent polymer and the touch electrodes are formed from indium tin oxide. Additionally or alternatively to one or more of the examples disclosed above, in some examples, the polarizer layers can include a polyvinyl alcohol layer, a tri-acetyl cellulose layer, and one or more optical retarder layers. Additionally or alternatively to one or more of the examples disclosed above, in some examples, the process can further comprise forming a shield layer on a second substrate; and coupling the second substrate to the polarizer layers. Additionally or alternatively to one or more of the examples disclosed above, in some examples, each of the substrate and the second substrate can have a thickness of 25 μm or less. Additionally or alternatively to one or more of the examples disclosed above, in some examples, the shield layer can be formed from indium tin oxide or silver nanowire. Additionally or alternatively to one or more of the examples disclosed above, in some examples, the second substrate can be coupled to the polarizer layers via an adhesive layer and lamination.

[0078] Some examples of the disclosure are directed to a method of forming a touch screen. The method can comprise forming a substrate; forming a touch sensor panel on the substrate; and forming polarizer layers on the touch sensor panel.

[0079] Although the disclosed examples have been fully described with reference to the accompanying drawings, it is to be noted that various changes and modifications will become apparent to those skilled in the art. Such changes and modifications are to be understood as being included within the scope of the disclosed examples as defined by the appended claims.

1. A touch screen comprising:
 - a display; and
 - a touch sensor panel disposed on the display, the touch sensor panel comprising:
 - a substrate formed from a flexible material; and
 - touch electrodes formed on one or more surfaces of the substrate;
 wherein a first portion of the substrate including the touch electrodes is planar and a second portion of the substrate is non-planar such that the substrate extends beyond a first dimension of the display.
2. The touch screen of claim 1, wherein the second portion of the substrate is a tab.
3. The touch screen of claim 1, wherein the second portion of the substrate wraps around from the touch sensor panel to a different layer in the touch screen, the different layer separated from the touch sensor panel by the display.
4. The touch screen of claim 1, further comprising:
 - a flex circuit coupled to the second portion of the substrate outside dimensions of the display.
5. The touch screen of claim 1, further comprising conductive traces disposed on the second portion of the substrate configured to route the touch electrodes disposed on the first portion of the substrate to touch sensing circuitry.
6. The touch screen of claim 5, wherein the conductive traces disposed on the second portion of the substrate comprise first conductive traces disposed on a first side of the substrate in the second portion of the substrate and second conductive traces disposed on a second side of the substrate in the second portion of the substrate.

7. The touch screen of claim 6, wherein the first conductive traces are disposed between an inner coating layer disposed on the first side of the substrate and an outer coating layer disposed over the first conductive traces.

8. The touch screen of claim 6, wherein the second conductive traces are disposed between an inner coating layer disposed on the second side of the substrate and an outer coating layer disposed over the second conductive traces.

9. The touch screen of claim 5, wherein the touch electrodes are formed from indium tin oxide and the conductive traces disposed on the second portion of the substrate are formed without indium tin oxide.

10. The touch screen of claim 5, wherein the touch electrodes are formed from silver nanowire and the conductive traces disposed on the second portion of the substrate are formed from silver nanowire.

11. The touch screen of claim 1, wherein the first portion of the substrate is coterminous with the display.

12. The touch screen of claim 1, wherein a third portion of the substrate is planar and separated from the first portion of the substrate by the display.

13. The touch screen of claim 1, further comprising a coating layer disposed on the one or more surfaces of the substrate, wherein the touch electrodes formed on the one or more surfaces of the substrate are disposed on the coating layer.

14. The touch screen of claim 13, further comprising a protective layer disposed on the one or more surfaces of the substrate, wherein the touch electrodes formed on the one or more surfaces of the substrate are disposed on the protective layer.

15. The touch screen of claim 1, wherein the second portion of the substrate is separated from the display such that a gap is formed between the second portion of the substrate and the display.

16. The touch screen of claim 1, wherein the substrate wraps around from the touch sensor panel to a different layer in the touch screen on a first side of the touch screen without the substrate wrapping around to the different layer in the touch screen on a second side of the touch screen, different than the first side of the touch screen.

17. The touch screen of claim 1, wherein a fourth portion of the substrate is non-planar such that the substrate extends beyond a second dimension of the display different than the first dimension of the display.

18. The touch screen of claim 17, wherein the fourth portion of the substrate wraps around from the touch sensor panel to the different layer in the touch screen.

19. The touch screen of claim 17, further comprising first conductive traces disposed on a first side of the substrate in the second portion of the substrate and second conductive traces disposed on a second side of the substrate opposite the first side of the substrate in the fourth portion of the substrate.

20. The touch screen of claim 19, wherein the first conductive traces are configured to route first touch electrodes of the touch electrodes on a first side of the substrate to touch sensing circuitry and wherein the second conductive traces are configured to route second touch electrodes of the touch electrodes on a second side of the substrate to the touch sensing circuitry.